

# RISA Technologies

Structural Modeling:  
An essential skill for engineers



Deborah Brisbin, P.E.





# Structural Modeling

Why is Structural Modeling an important part of the design process?

- Structural Model must match as-built framing configuration & loading
- Interdisciplinary models must contain relevant information

Common Pitfalls in Structural Software Modeling:

- “Black Box”
- “Garbage In – Garbage Out”





# Structural Modeling

What percentage of your design work uses software?

25%

50%

75%

90%





# Structural Modeling

## Important things to remember about Structural Modeling

- Computer programs do not have engineering judgment
- Non-experienced engineers do not have a “feel” for how the structure will behave
- Every person in your office can’t know all aspects of your software
- Establish what information you want to transfer to your partners before starting your design



# Physical Members

How do you model continuous girders, truss chords & continuous columns?

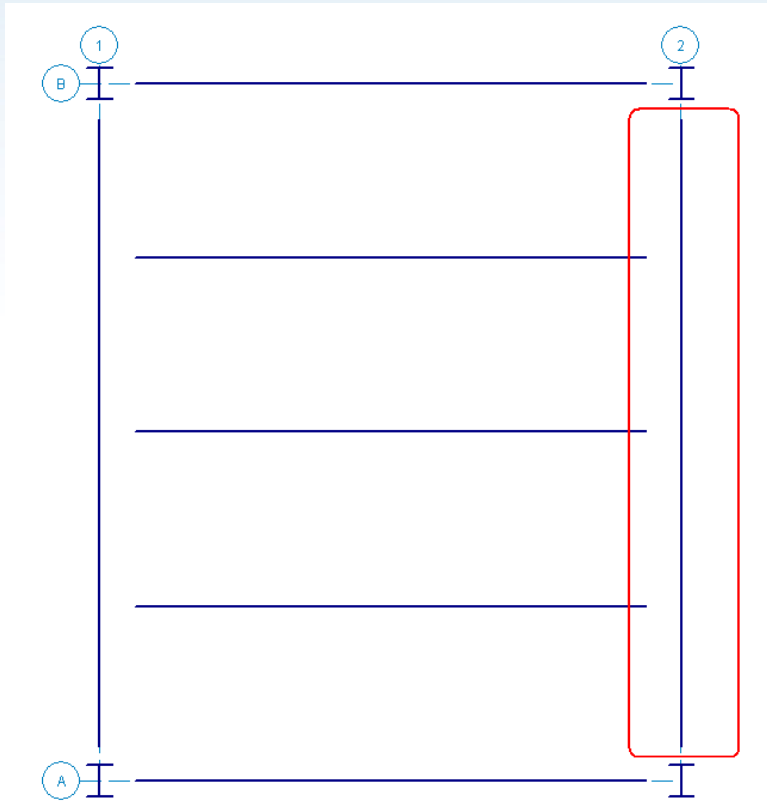

# Physical Members

Option 1: Individual Members

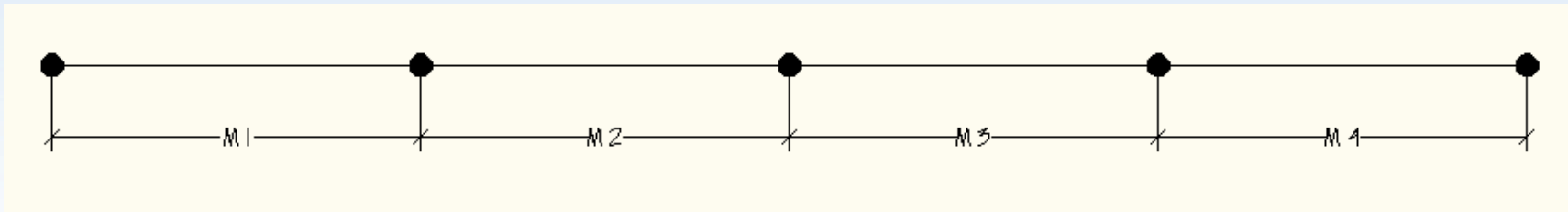

Option 2: Physical Member

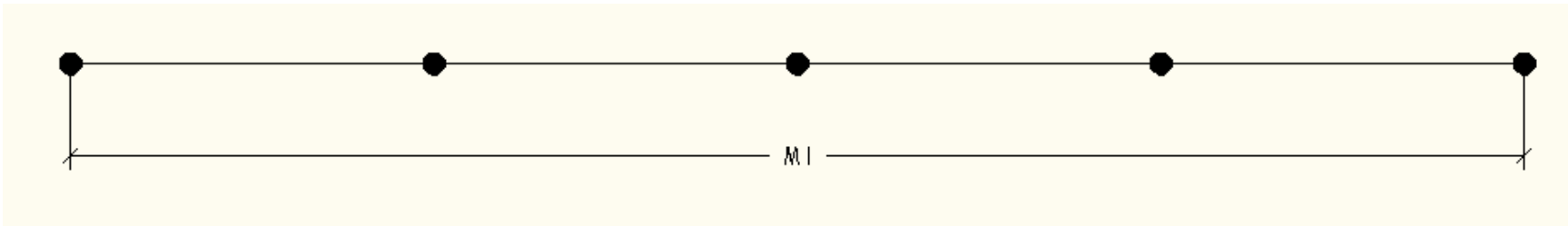

# How do Options 1 & 2 effect your design?

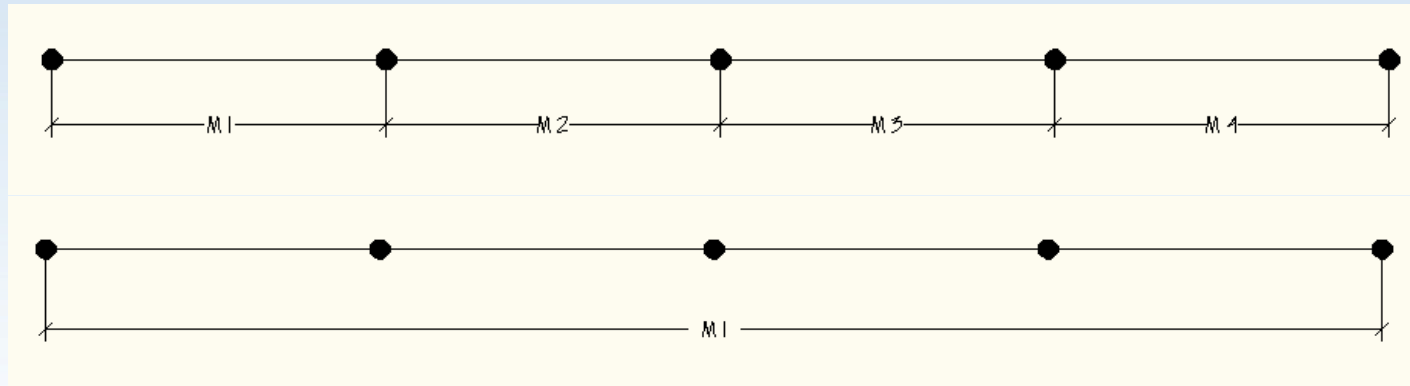

## K factors

- RISA can automatically calculate this factor for you. Calculated K values are based on the on the member's sway condition and end release configuration.

AISC Chapter C Table C-C2.2

Table Case	End Conditions	Sidesway?	K-Value
(a)	Fixed-Fixed	No	.65
(b)	Fixed-Pinned	No	.80
(c)	Fixed-Fixed	Yes	1.2
(d)	Pinned-Pinned	No	1.0
(e)	Fixed-Free	Yes	2.1
(f)	Pinned-Fixed	Yes	2.0





# How do Options 1 & 2 effect your design?

## K factors

What are the end conditions for each segment vs. the entire member?

Both Columns  
Pinned- Pinned

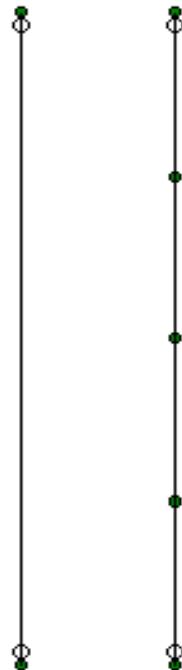

K-Factors

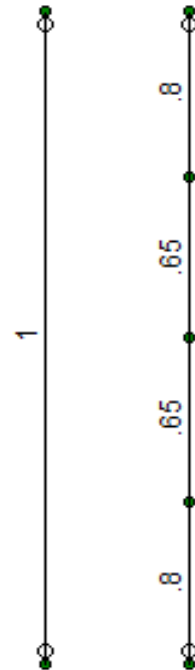



# How do Options 1 & 2 effect your design?

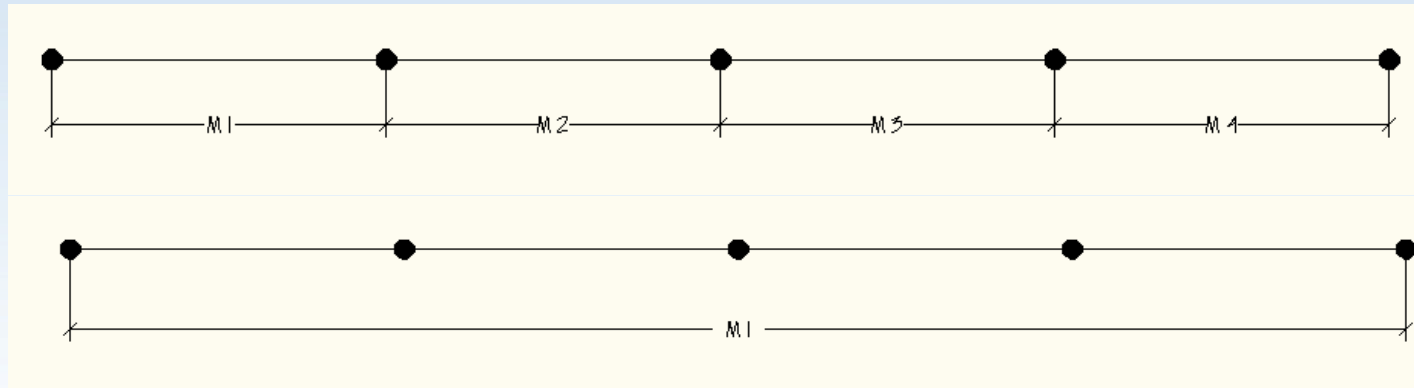

## Unbraced Length

- The default member length is the full length of the member.
- RISA can automatically calculate the brace points-  
“Segment”
- Or manually enter your unbraced length



# Unbraced Length

Double-click on the member to get the Design tab information

Column type buckling  
**about** the member local axis

Flange buckling due to flexure  
relative to the top & bottom  
of the member

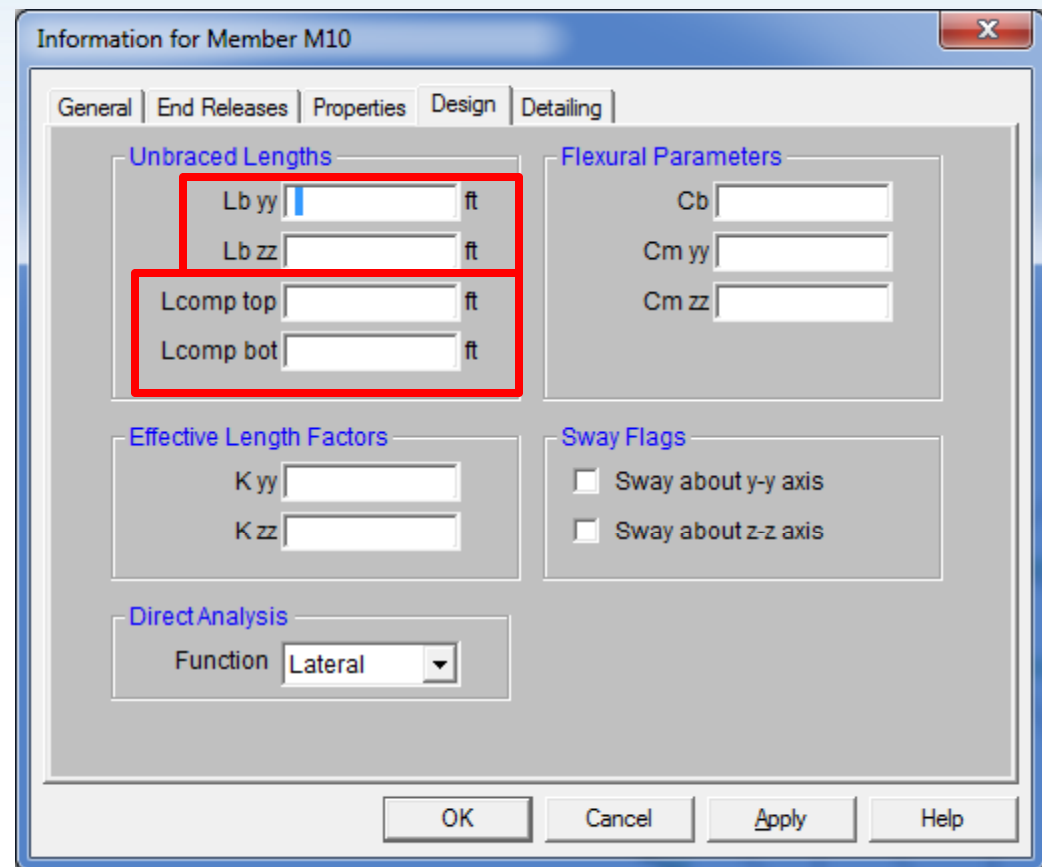

Information for Member M10

General | End Releases | Properties | Design | Detailing

**Unbraced Lengths**

Lb yy  ft

Lb zz  ft

Lcomp top  ft

Lcomp bot  ft

**Flexural Parameters**

Cb

Cm yy

Cm zz

**Effective Length Factors**

K yy

K zz

**Sway Flags**

Sway about y-y axis

Sway about z-z axis

**Direct Analysis**

Function

OK Cancel Apply Help

# Unbraced Length

How does Unbraced Length effect your results?

- Axial Design Results

$$\frac{KL}{r}$$

- Bending Design Results

- Is the top or bottom of the member braced for bending?

- How do you tell the “top” from the “bottom” of the member?

The “top” of the member is in the direction of the positive y axis

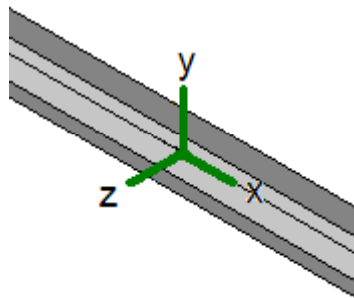

# Unbraced Length

How do local axes affect the Unbraced length?

- How is the “top” and “bottom” of the member determined?
- How are the weak and the strong axis related to the local coordinates?
- When you rotate the member how does this affect the results?

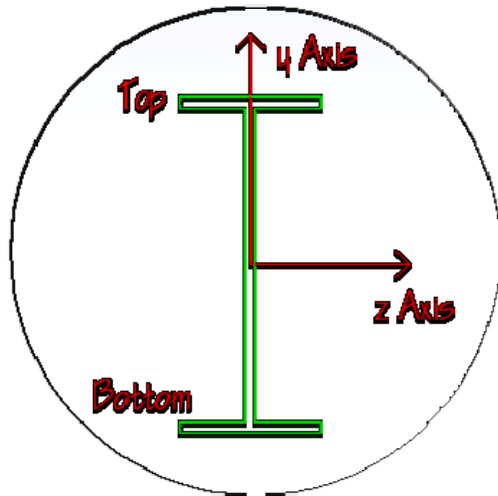

Rotate:  $0^\circ$

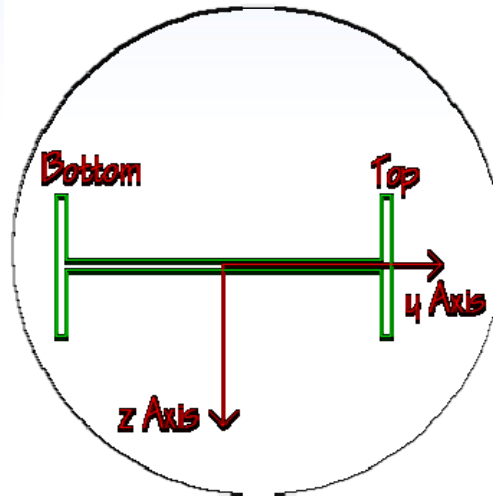

RISA-3D:

Rotate:  $90^\circ$

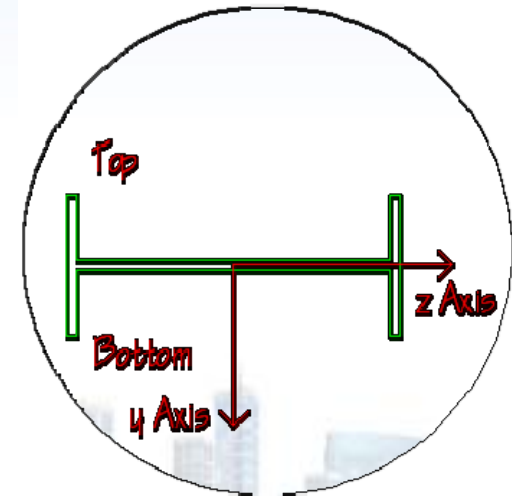

Other Software:

Rotate:  $90^\circ$

# Unbraced Length

How do connection types effect unbraced lengths?

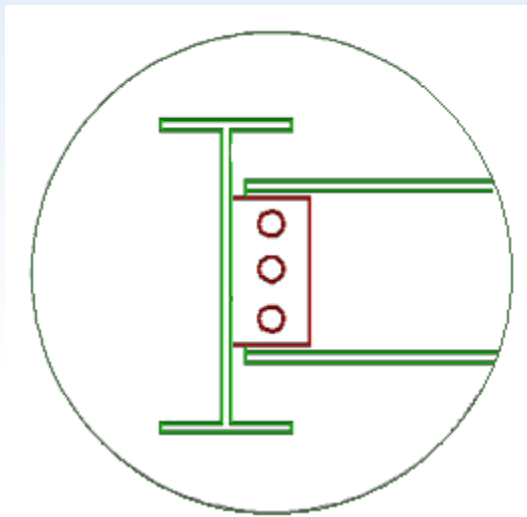

Top Flange: No  
 Bottom Flange: No  
 Weak Axis: Yes  
 Strong Axis: No

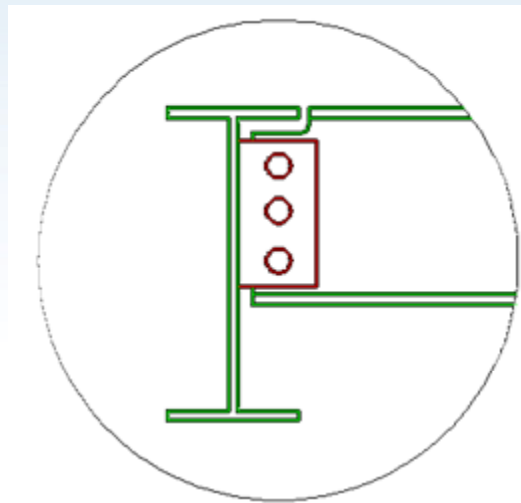

Top Flange: Yes  
 Bottom Flange: No  
 Weak Axis: Yes  
 Strong Axis: No

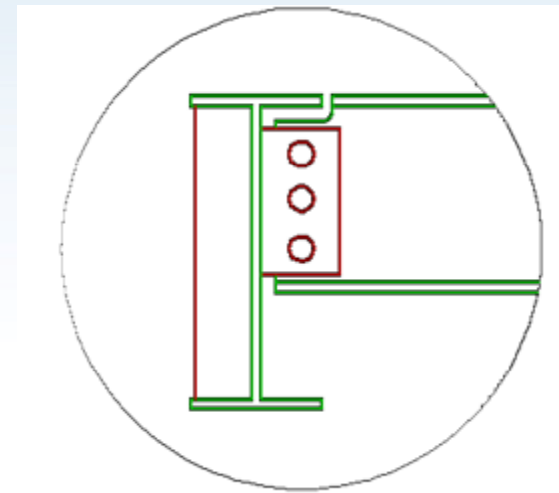

Top Flange: Yes  
 Bottom Flange: Yes  
 Weak Axis: Yes  
 Strong Axis: No



# Unbraced Length

How does construction type effect Unbraced length?

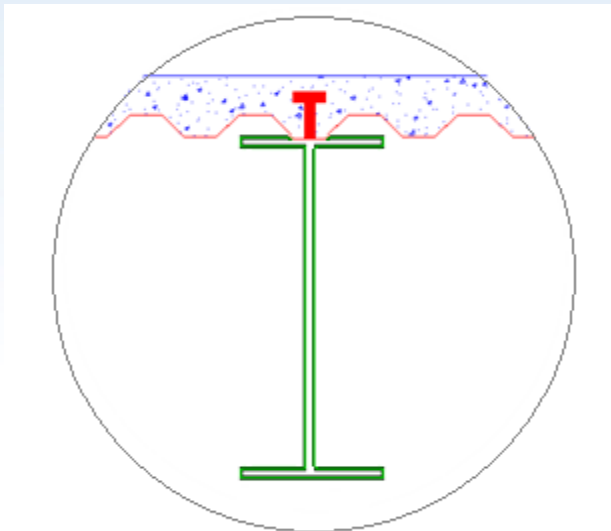

Top Flange: Yes  
Bottom Flange: No  
Weak Axis: Yes?  
Strong Axis: No

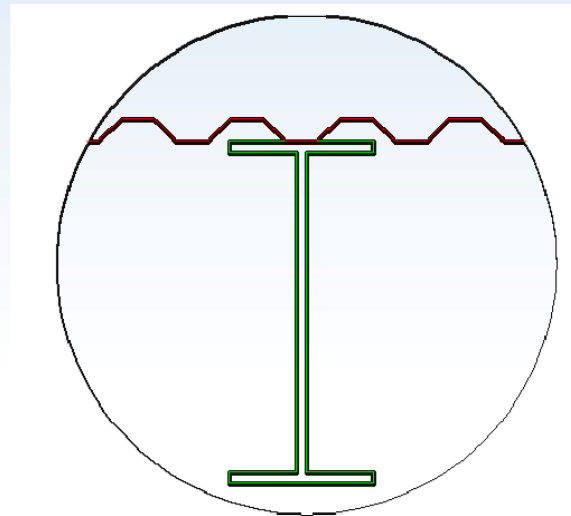

Top Flange: Yes/No  
Bottom Flange: No  
Weak Axis: No  
Strong Axis: No



# Plate Modeling

What are the Rules of Thumb for plate modeling?

## Rule 1: Plate Size

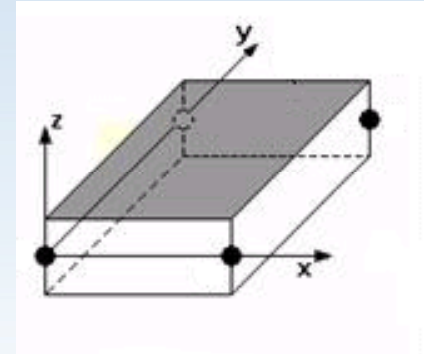

### Quadrilateral Elements

length: width  $< 9$

thickness : length  $< 3$

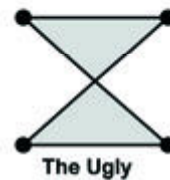
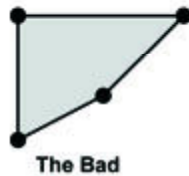
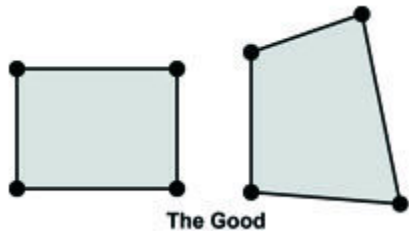

### Triangular Elements

length: width  $< 9$

$\Theta < 135^\circ$   
( $90^\circ + 45^\circ$ )



# Plate Modeling

## Rule 2: Plate Connectivity

- Plates can only transfer forces at their corner nodes

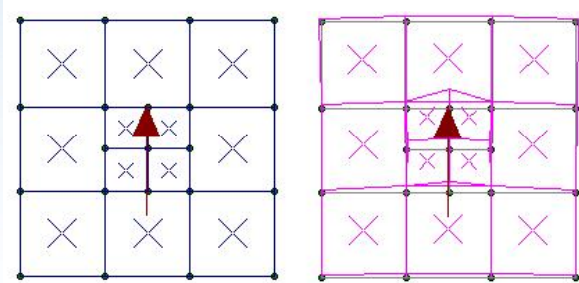

- Transition meshing is important for proper load transfer

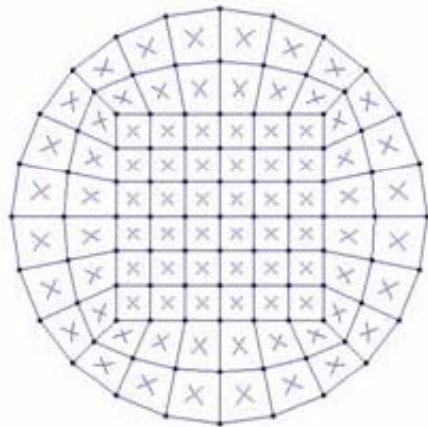

Square to Round

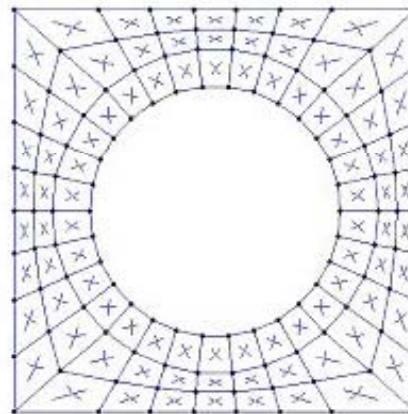

Round to Square





# Plate Modeling

## Rule 3: Mesh Size

- Decreased mesh size needs to be uniform

<u>Original Mesh Size</u>	<u>New Mesh Size</u>
1 x 2	2 x 4
2 x 2	4 x 4
1 x 3	2 x 6
2 x 3	4 x 6

- Rule of 10%  
There should be less than 10% difference between results for each mesh iteration.

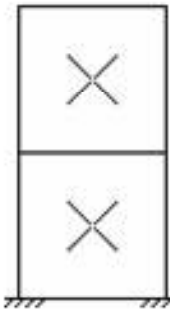
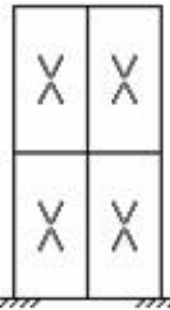
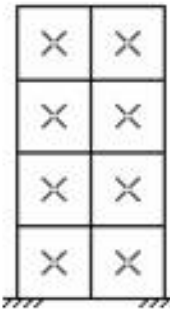
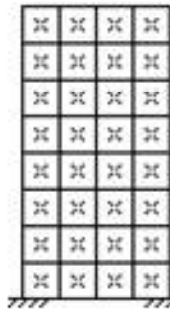

# Plate Modeling

					
Element Mesh	1x1	1x2	2x2	2x4	4x8
Deflection (in.)	4.54	8.07	8.26	10.43	11.29
Error	62%	33%	31%	13%	6%
Stiffness K (kips/in)	3304.0	1858.7	1816.0	1438.2	1328.6

1 → 2 → 3



# Plate Modeling

## Rule 3: Mesh Size

- Plate Force Contours

There should be 3 or fewer contour changes  
in each plate



# Plate Modeling

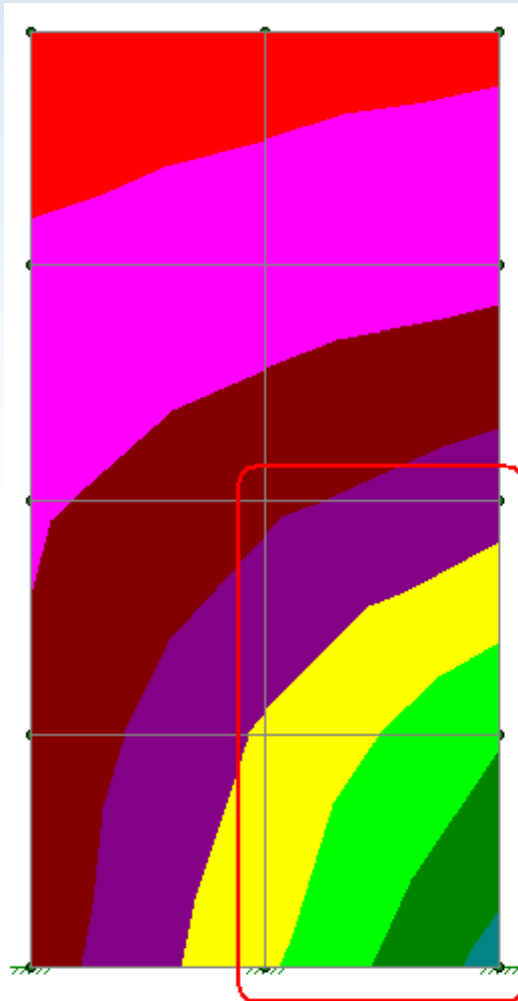

4 Contours per Plate

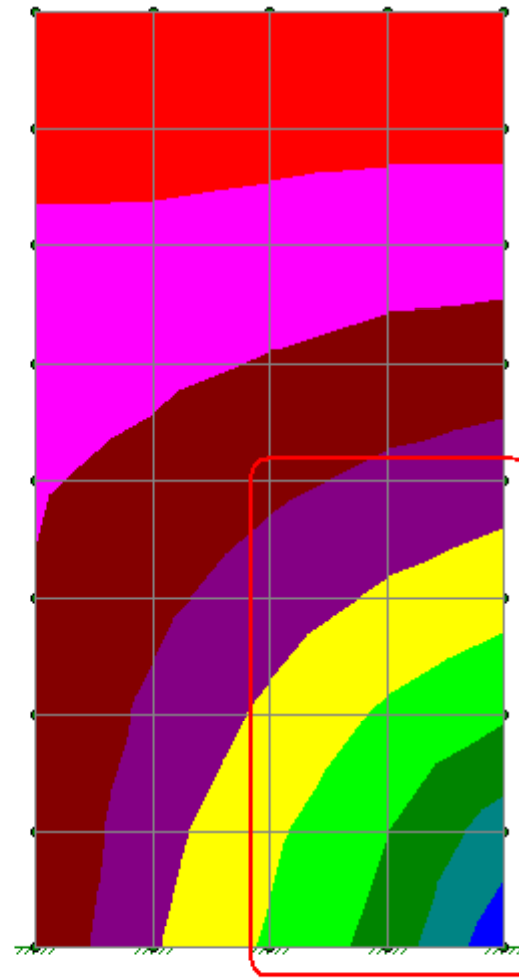

2-3 Contours per Plate

# Plate Results

What are the Rules of Thumb for reviewing plate results?

## Rule 1: Know the Plate Local Axes

- Are the forces displayed in the Plate Local Axes or the Global Axes?

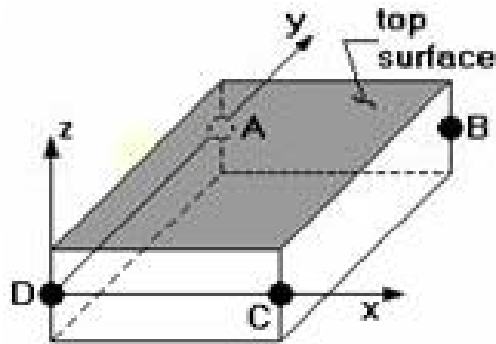

**4 Node Quad  
Local Axes**

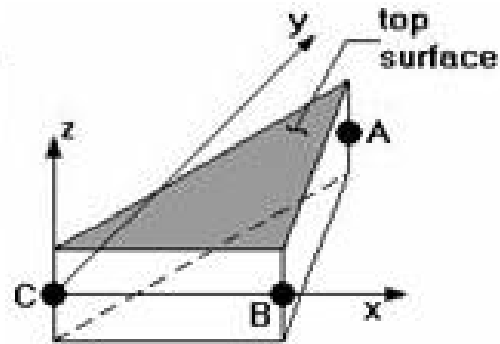

**3 Node Triangle  
Local Axes**



# Plate Results

## Rule 2: Know how the Forces are displayed

- On a per unit length basis?
- Total forces on the plate?

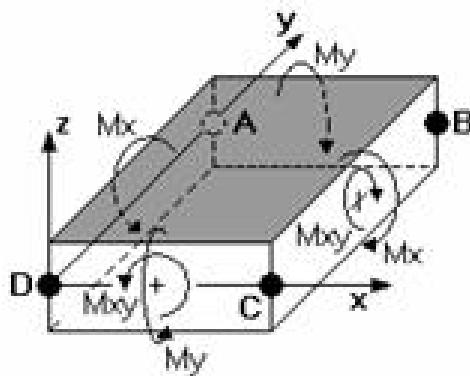
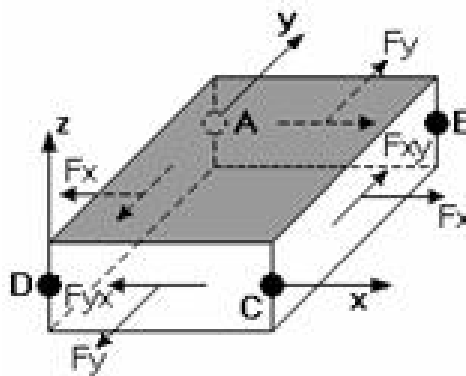

Plate Moments



Plane Stress Forces



# Plate Results

## Rule 3: Know what tools are available to simplify reading Plate results

- Automatic meshing
- Force and/or design strips
- Display forces along a user defined line

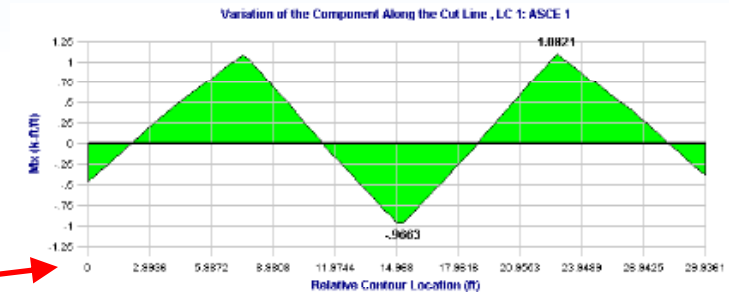
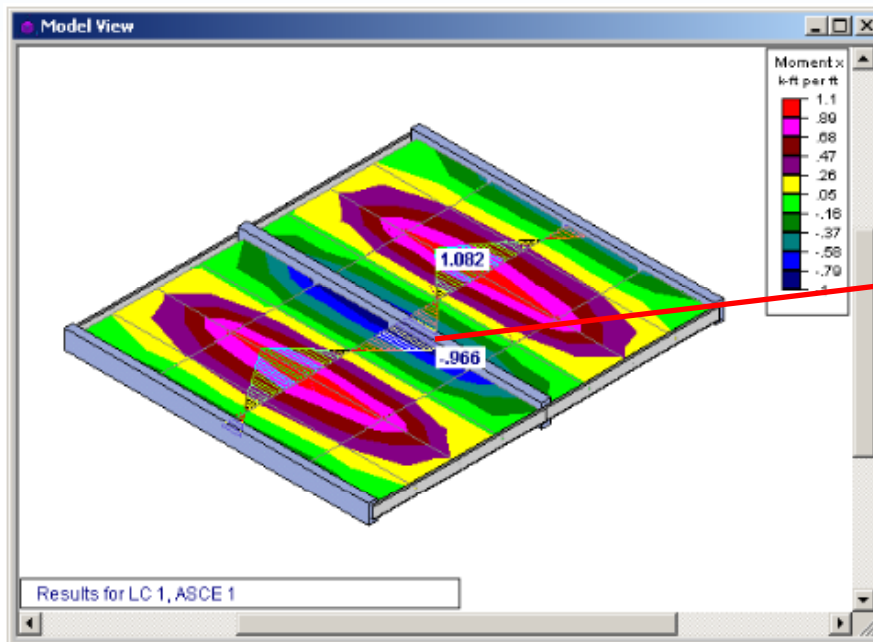

# Understand your Results

Make sure your results make “Sense”

- Check your Deflected Shape
- Check your Joint Reactions – Total Loads = Total Reactions
- Understand the Code Check

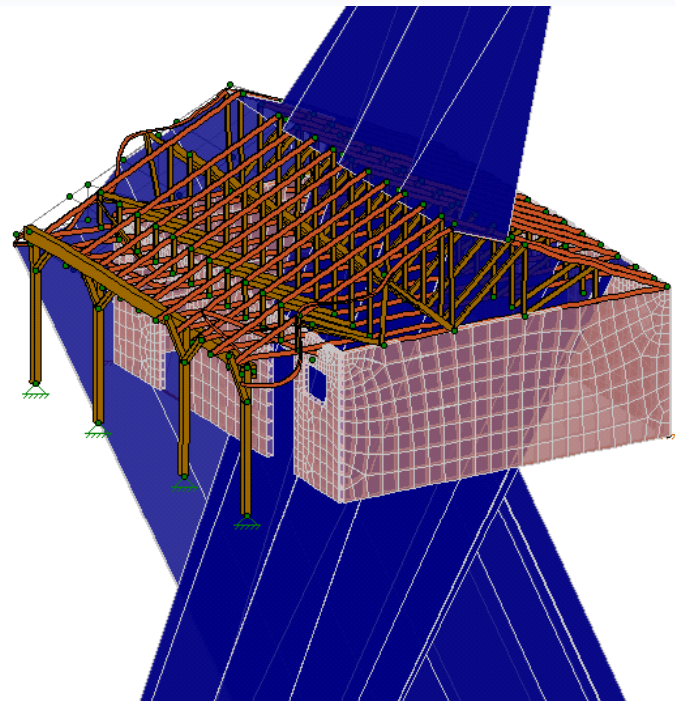
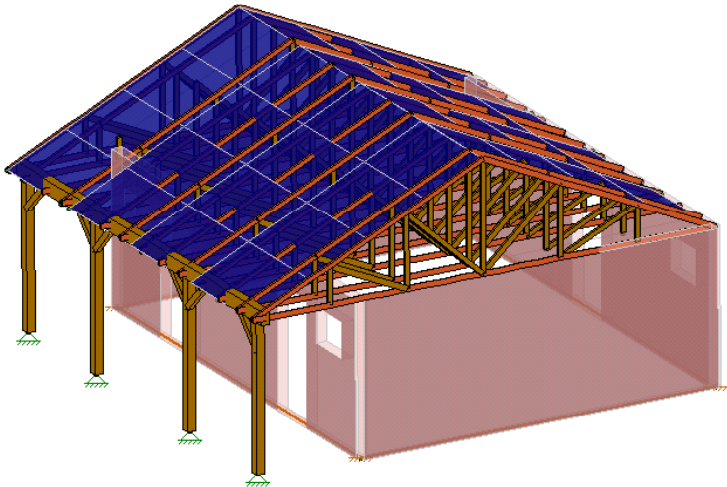



# Integration

What other software will you need to integrate with?

- BIM
- CAD
- Steel Detailing
- Plant Design Systems

What format will you be using to integrate?

- Direct links via an API
- DXF
- CIS/2
- IFC



# Integration

What information does your software transfer?

- Geometry
- Sizes
- Materials
- Loads
- End Reactions

What information is vital to correctly transfer information?

- Member Offsets: Top of Steel or Centerline?
- Brace Points: Model vs Construction
- Modeling Simplifications



# Integration

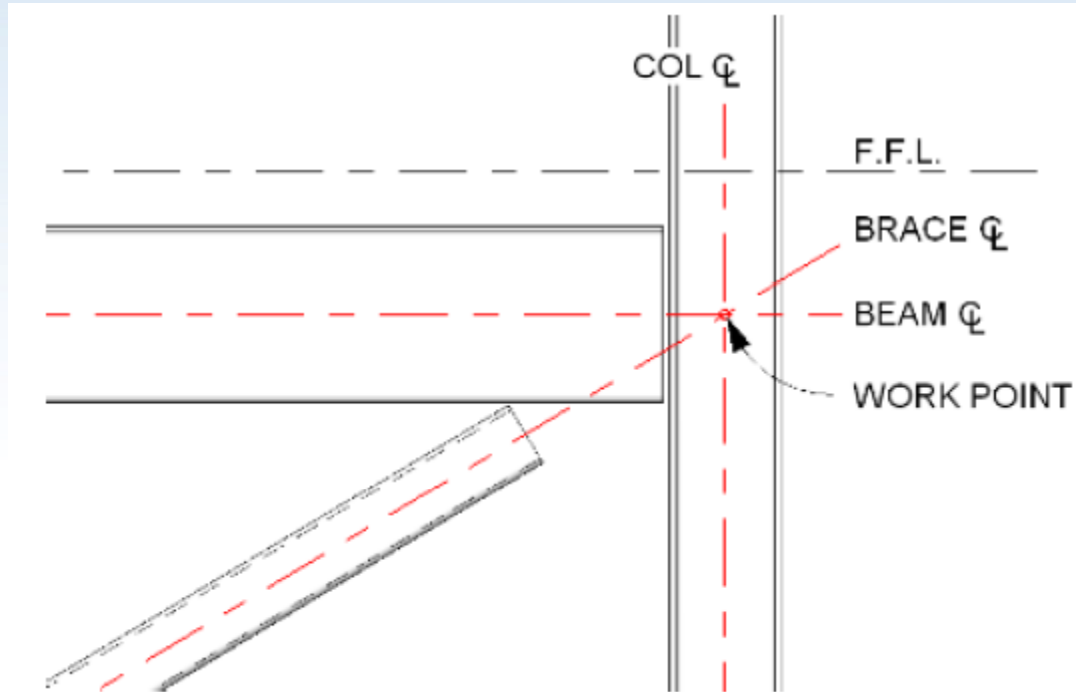

Analytical Assumption



# Integration

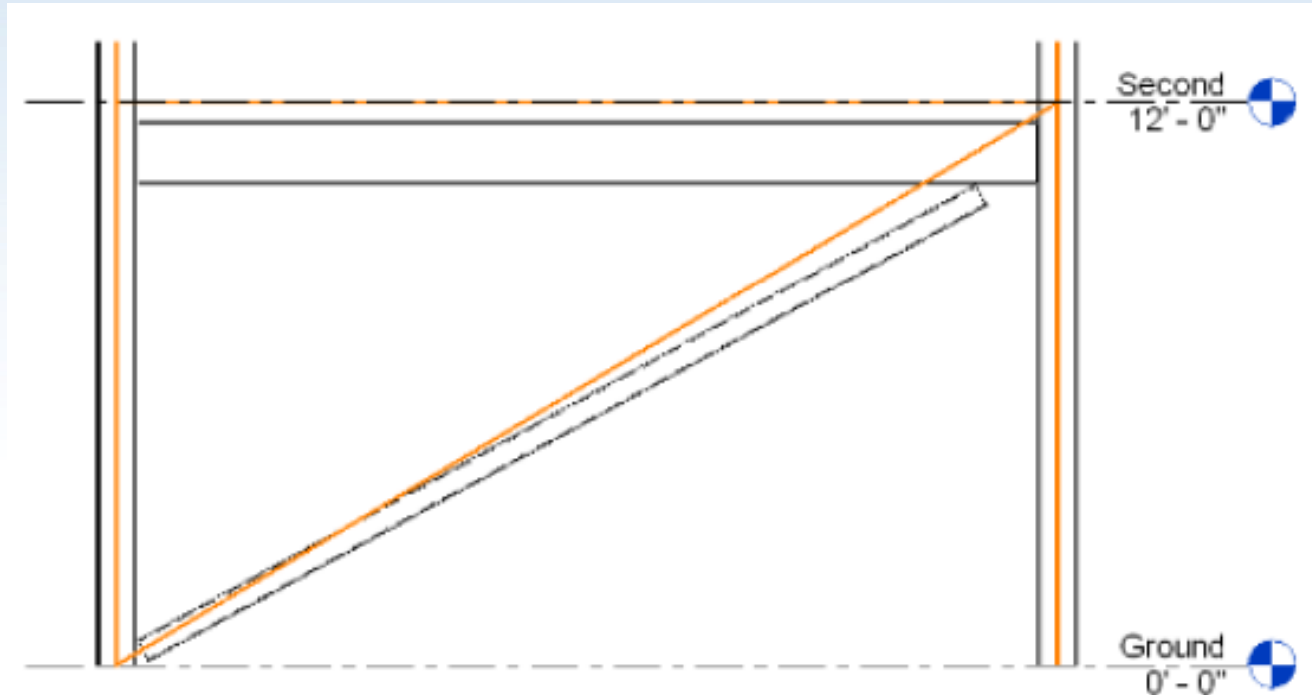

Modeling Assumption



# Integration

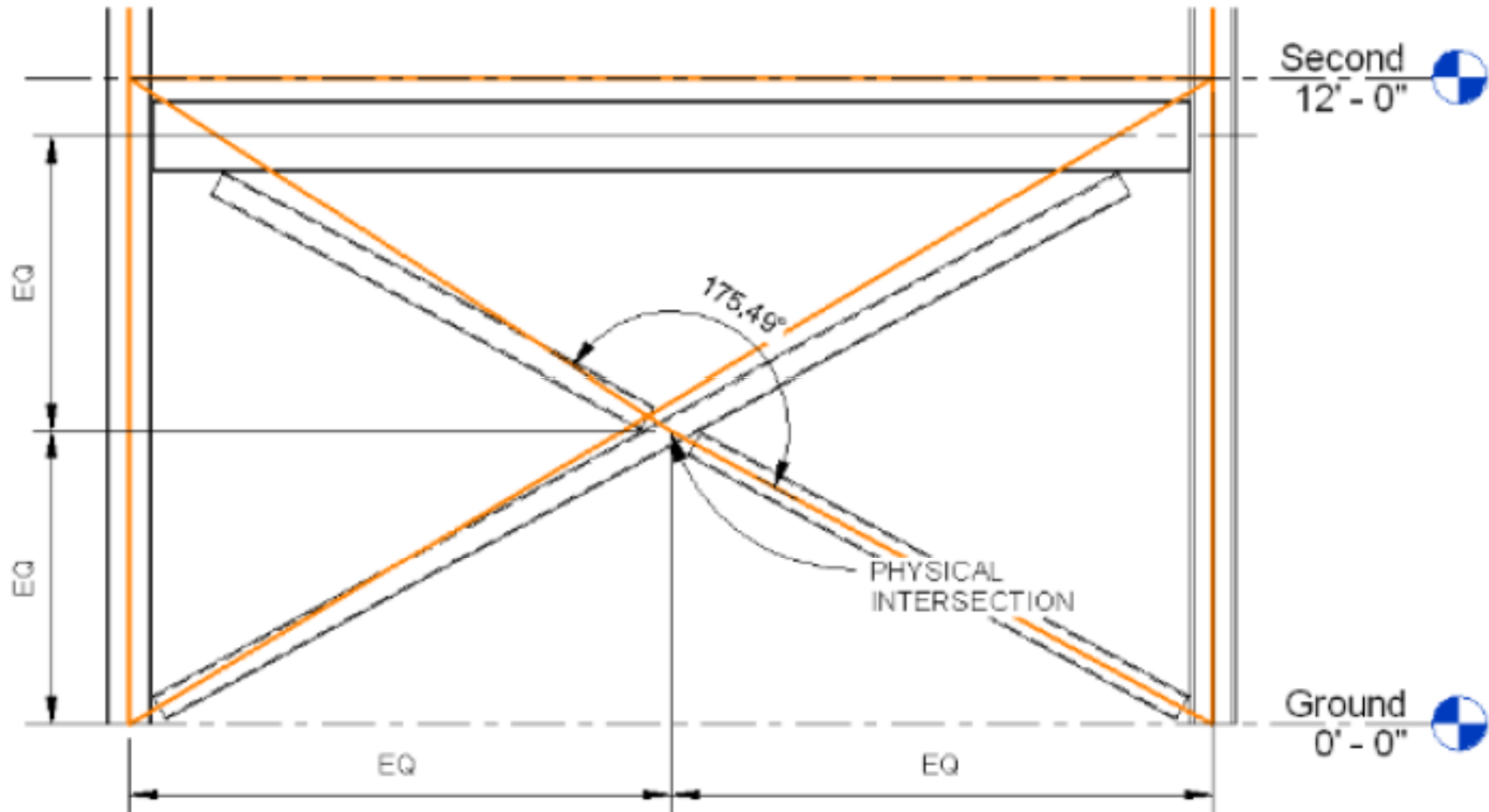

# Integration

Who needs to know about these modeling assumptions?

- Detailer?
- Fabricator?
- Contractor?

Communication is **VITAL** to the design process!

- When transferring electronic files you **MUST** communicate with your partners about your modeling assumptions





# Structural Modeling

How can you apply these theories to your office?

- Assign a “champion” for each software program you use
- Attend training specifically for your software
- Create a list of “modeling rules” for your office
- Establish what information you’d like to transfer to your partners
- Utilize your software support with questions about modeling





# Structural Modeling

## Questions?

- Please let us know if you have questions.
- We will answer as many questions as time permits during the webinar.
- Once the webinar is closed, we will post all Q&A's to our website: [www.risatech.com](http://www.risatech.com)
- For further information, contact us at: [info@risatech.com](mailto:info@risatech.com)

