

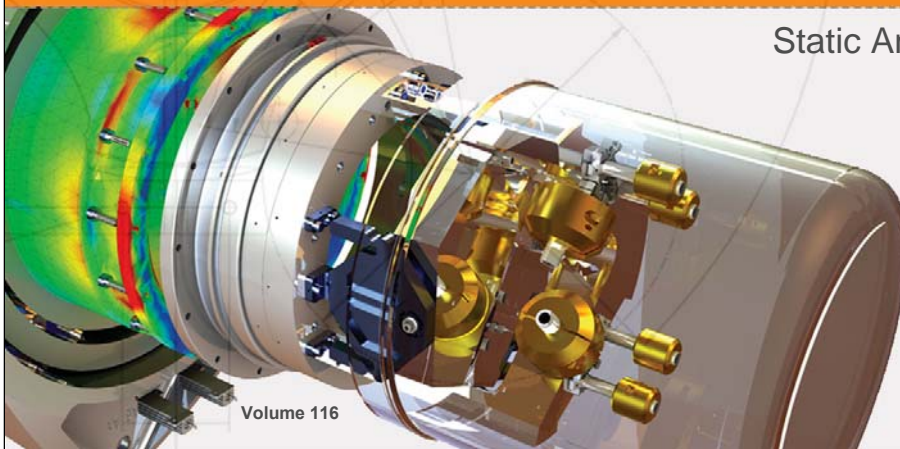

# The COSMOS Companion

## Static Analysis of Welds and Weldments



Volume 116



Image courtesy of National Optical Astronomy Observatory, operated by the Association of Universities for Research in Astronomy, under cooperative agreement with the National Science Foundation.

## What is the COSMOS Companion?



- The COSMOS Companion is a series of short subjects to help design engineers build better products with SolidWorks Analysis
- Video presentations and accompanying exercises
- A tool for Continuous Learning on your schedule
- Pre-recorded videos are accompanied by a more detailed webcast with Q & A
  - Download videos and review webcast schedule at:
    - [http://www.cosmosm.com/pages/news/COSMOS\\_Companion.html](http://www.cosmosm.com/pages/news/COSMOS_Companion.html)
- It is not an alternative to instructor-led introductory training
  - We highly recommend you take a course with your local reseller to build a solid knowledge base

© 2006 SolidWorks Corp. Confidential.

2

If you are new to the COSMOS Companion, a few comments on the program are warranted. The COSMOS Companion series was developed in response to the request from many of our users for more detailed information on specific and/or new functionality within the COSMOS products. Additionally, many users have been asking for clarification of common design analysis questions to enable them to make more representative analysis models and make better decisions with the data. What's more, users have asked for this material to be made available in a variety of formats so they can review it how and when they wish. To address this, each COSMOS Companion topic has been pre-recorded and made available thru the COSMOS Companion homepage as a downloadable or streaming video with audio, as static PDF slides for printing, or as a live webcast enabling attendees to ask questions and engage in additional discussion. We are trying to provide continuous learning on your schedule so you can be as effective and efficient as possible when using COSMOS for design analysis and validation.

It is important to note that this material is not developed as an alternative to instructor led training. We still believe that the best introduction to any of the COSMOS products is in a class led by your reseller's certified instructor. In this program, we are hoping to build on the lessons learned in your initial training. In fact, we will make the assumption that you have basic knowledge of the interface and workflow from intro training or equivalent experience. We will try not to repeat what was taught in those classes or can be found in the on-line help but to augment that information.

## Topics to be Covered...



- General Discussion on Welds & FEA
- Calculating Stresses on Welds Using FEA
- Throat Shear Method for Static Weld Sizing
- CAD Modeling Tips for Proper Weld Load Path

© 2006 SolidWorks Corp. Confidential.

3

In this edition, we'll be reviewing the role of FEA in modeling welds and weldments. We'll discuss what you can expect and, more importantly, what you can't expect from results on a model where welds are explicitly modeled.

The bulk of the session will be reviewing the Throat Shear method for sizing welds in a static load case using forces extracted from the COSMOSWorks model. This technique is well documented and relatively insensitive to mesh size. A discussion of weld fatigue, which requires a completely different methodology will be discussed in a later COSMOS Companion unit.

Finally, we'll discuss techniques for incorporating the weld bead in solid and shell models and when this is appropriate.

Remember, this isn't a discussion on the SolidWorks techniques required to construct a weldment, it is an overview on determining the characteristics of the structure and the acceptability of the welds themselves.

## What FEA Likes to See...



- Machined steel parts from gravity cast blanks
- Ground and polished surfaces with no defects or imperfections
- Heat treated to remove any residual stresses from machining process
- Numerically controlled machining so that the dimensions are consistent from one part to another
- Why?
  - Response is VERY predictable and consistent

© 2006 SolidWorks Corp. Confidential.

4

Before talking about welds, let's briefly discuss the "ideal" part for FEA. Remember that any COSMOSWorks model is a snapshot of an idealized configuration that may or may not bear any resemblance to the actual manufactured part. Your best chance at a 1:1 correlation without much interpretation is a steel part machined from gravity cast blanks. These parts are inherently free from initial residual stresses. You'd want to make sure that all surfaces were polished to remove any coarseness or imperfections since it is unlikely you will include these in your FEA model. After these operations, you should heat treat your part one last time to remove any residual stresses that might have been generated by the machining process. Unless you intentionally include pre-stress, all FEA models assume a uniform zero initial stress state. Finally, your parts should be machined using a precision numerically controlled system to maximize the chance that every part is identical.

This gives you the most predictable and consistent part-to-part performance. Remember that no matter how many times you run the COSMOSWorks model, you'll keep getting the same answer. If this isn't true for testing multiple samples of the "same" part, you must acknowledge there will be differences between what you analyze and what you test.

## Why Welds are Nothing Like This...



- Welds vary from part to part and even within a given weld due to:
  - Chemistry: Carbon, Manganese, Hydrogen
  - Temperature: Weld, Preheat, Cooling
  - Base Material: Porosity, Composition
  - Weld Geometry: Penetration, Convexity, Continuity, Grinding
  - Heat Affected Zone: Uniformity, Property Degradation (Ductility)
  - Microcracking at perimeter of Weld
  - Residual Stress after cooling
  - Part Geometry: Surface Finish, Alignment, Warpage



Big Weld Says...  
"Don't Get Too Confident in Weld Results!!"

© 2006 SolidWorks Corp. Confidential.

5

While few of us have the luxury of this part-to-part consistency, the variability is not usually so great that reasonable predictions can't be made based on the FEA results. This is not the case with welds. All the variables listed on this page come into play on every weld. Most welds vary in several of these ways along the length of single weld.

What they look like, what their made of, and what they do to the base parts is so difficult to nail down that it is unreasonable to assume that the stresses shown on or near an explicitly modeled weld bear any resemblance to the response you might get in an actual part.

## Can You Ever Know What Stress a Weld Sees?



- Only in the most controlled conditions
- Rarely from a predictive standpoint
- Possibly from a failure analysis approach where sample is available for measurement and testing

### **Can more careful and detailed FEA overcome the variability inherent in a weld to allow better prediction?**

© 2006 SolidWorks Corp. Confidential.

6

If stresses on explicitly modeled welds can't be used for predictive purposes, it is reasonable to ask why model welds in an assembly at all. Actually, in most cases, leaving the weld geometry out is recommended since the local results won't provide good data and if they're there, a casual observer of your results might be tempted to draw conclusions without the knowledge those results are questionable. We'll discuss other reasons to include weld geometry in your model at the end of this presentation but at this stage, let's focus on weld geometry and stress results.

There have been a few cases in my experience where weld geometry was included and the results on these features were key to design decision making. In one case, we were evaluating a known failure of a large, low aspect ratio lug welded to a similarly large part where we could measure the sample geometry, measure penetration, and perform material testing on the local properties. In this case, using this data from the failed system, we were able to determine stresses that were indicative of the observed failure and then correct the problem. Without this detailed information, the stress calculations would have been suspect for the reasons stated previously. In the other cases, we focused the project on trend results where we acknowledged the stress results were suspect but assumed the variability would be 'consistent' and focused on reducing calculated stress in and near welds, expecting the actual system would experience a similar reduction in stress. Including weld geometry in trend studies is still a valid approach.

However, for making predictions of weld acceptability, can the analysis results be used? Can the variability in welds be overcome with more diligent modeling to facilitate prediction? Let's look at a few more aspects of stress results on welds.

## Calculated Stresses at Welds



- Welded intersections in FEA models are notorious for singular or unreasonably high stresses

© 2006 SolidWorks Corp. Confidential.

7

First of all, anyone who has actually included weld geometry in a solid analysis model has probably observed one or several “hot spots” or stress singularities at the transition from the weld bead to the base geometry. Are these stresses controlling? If not, how far from these stresses can you start to evaluate?

## Calculated Stresses at Welds

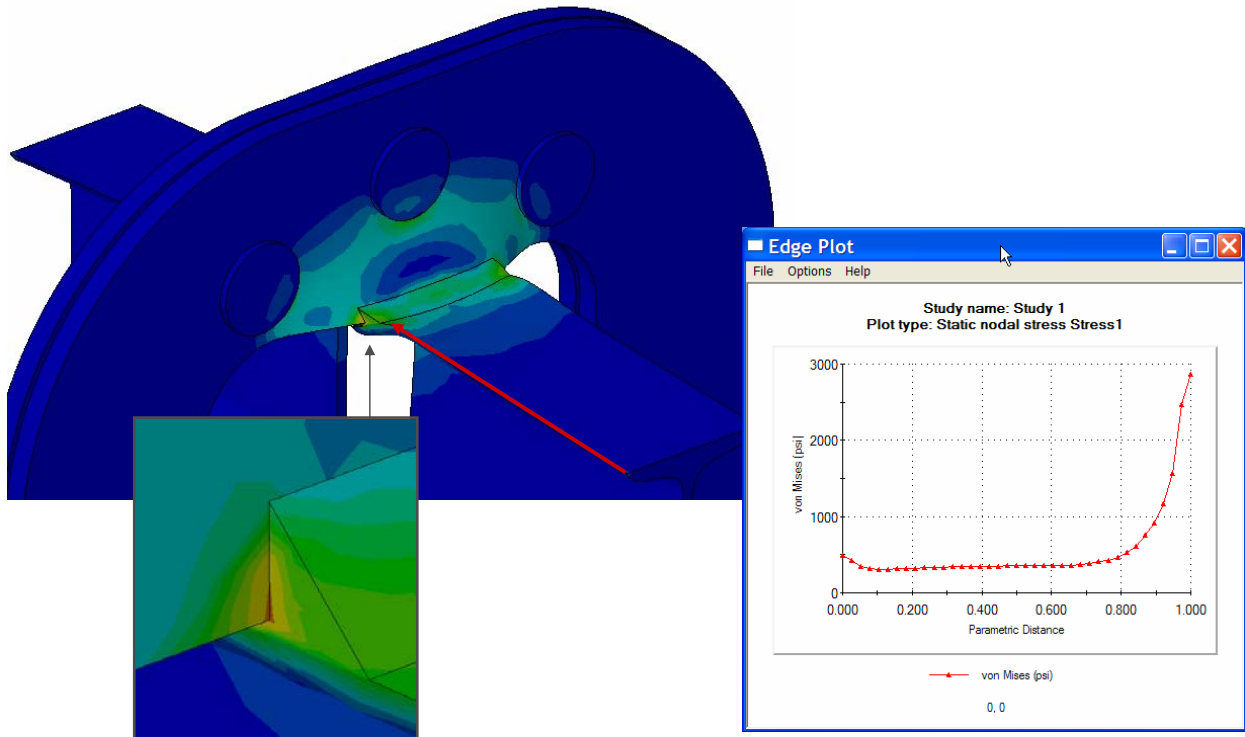

© 2006 SolidWorks Corp. Confidential.

8

In this case, you can see that the hot spots mentioned exist and are caused by two things. The geometry has sharp corners and is clearly unlike any weld you are likely to see coming from the shop. These sharp corners are numerical stress risers and may or may not be indicative of the actual part. The other reason is that a weld bead area is typically much more stiff than the surrounding metal and error is likely in any FEA model where stiffness transitions across a large gap.



## Calculated Stresses at Welds



- Welded intersections in FEA models are notorious for singular or unreasonably high stresses
- Stress estimation directly from FEA requires an initial estimate of weld size

© 2006 SolidWorks Corp. Confidential.

9

Another characteristic of FEA models of welds is that any result requires an initial estimate of the size of the weld. The stress near a weld will vary with the weld size chosen. This is contrary to the concept of predictive design analysis.

## Calculated Stresses at Welds

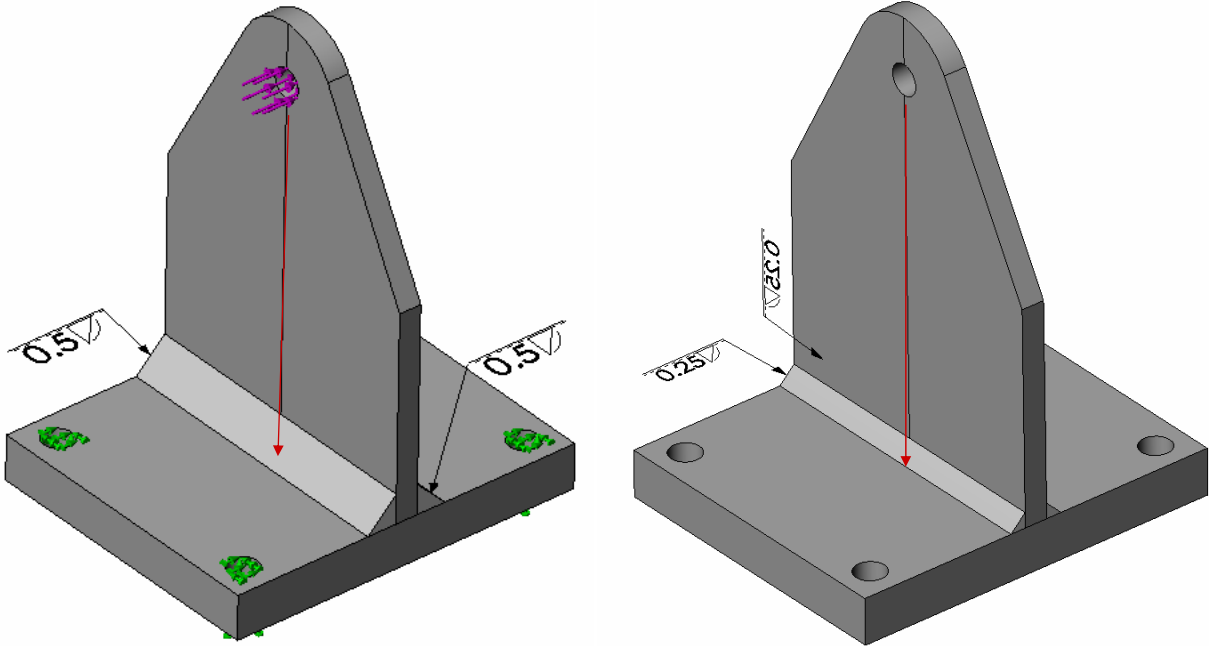

© 2006 SolidWorks Corp. Confidential.

10

In this example, the stress in a lug is calculated using a  $\frac{1}{4}$  inch weld and a  $\frac{1}{2}$  inch weld. The stress is plotted along the split line shown.



# Calculated Stresses at Welds

0.5 in Weld

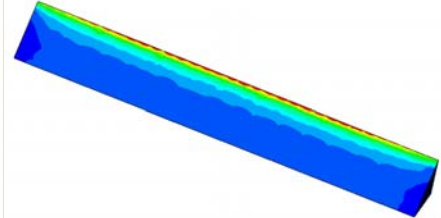
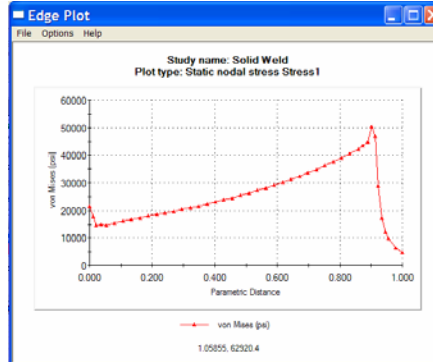
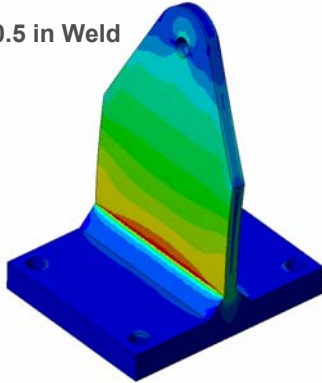

0.25 in Weld

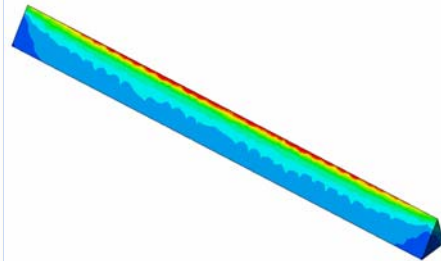
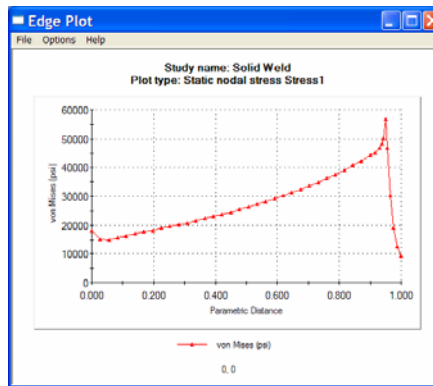
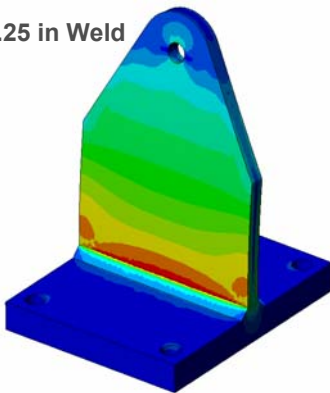

© 2006 SolidWorks Corp. Confidential.

The stress magnitude and distribution changes with the different weld sizes so even if the stresses can be considered reliable, the model can only give you a go-no go. It can't easily be used to predict weld size.

## Calculated Stresses at Welds



- Welded intersections in FEA models are notorious for singular or unreasonably high stresses
- Stress estimation directly from FEA requires an initial estimate of weld size
- For the reasons stated previously, welds in production bear little or no resemblance to welds in a CAD or FEA model

© 2006 SolidWorks Corp. Confidential.

12

Finally, as stated previously, even if you were able to resolve these other issues, the geometry, local properties and residual stresses in your model will not & CAN NOT match welds coming out of manufacturing for all parts being shipped.

## Calculating Weld Size Using Loads



- Throat Shear Method - Treat welds as lines
  - No estimate of throat area required up front
  - Allowables from standards such AWS D1.1 available
    - Allowables account for weld variability
  - Uses Normal, Bending, and Shear forces instead of stress
    - Forces are more readily attainable and less sensitive to geometry
    - Forces are not mesh dependent

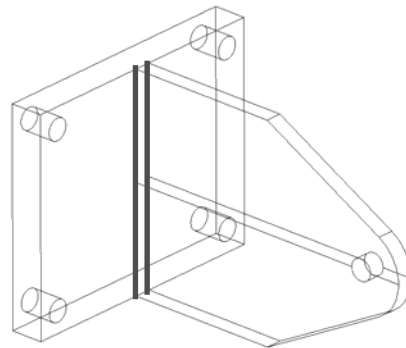
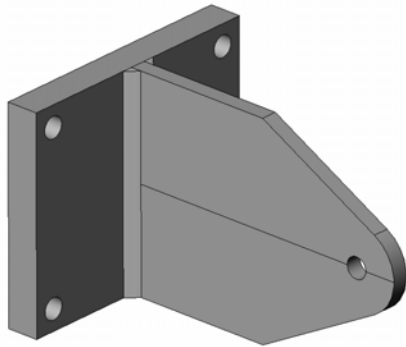

© 2006 SolidWorks Corp. Confidential.

13

If stress results can't be used for prediction, what other options are available? Interestingly enough, it has always been a common practice in weld design to estimate the resultant load being carried through a weld and then use this load, the 'demand', to choose a weld with sufficient 'capacity'. One limitation of this technique is accurate approximation of loads in a more complex system. Once the load path and geometry exceed the limits of standard hand calcs for bending and shear, FEA is the best, maybe the only, way to determine loads through a weld.

This method of using the loads in a weld to size a weld is often called the Throat Shear method. One key aspect of this method is that the weld bead is treated as a line and all the loads thru that line are reduced to a resultant load per unit length. This technique eliminates the need to make an initial estimate of weld size since it doesn't figure into the calculations but instead falls out of the process. Since this method is commonplace, there are documented sources of allowable strength per unit length in a weld based on weld type, service type, and electrode used. These standard allowables are based on test results, not theory, so the variability of welds is accounted for statistically in the recommendation.

One of the biggest benefit is that it uses loads and not stresses. Forces and moments in an FEA model are easily attainable, less sensitive to local geometry, and not mesh dependent. If you mesh your part using 3 different default element sizes, the reaction loads at your restraints will remain the same. Therefore, you don't need to worry about convergence at welded intersections since stresses aren't considered.

A final note is that this method doesn't require you to build explicit weld geometry. It is most easily applied to shell models and you can simply build your mesh with welded parts intersecting. If you wish to use this method for solids, you may need to take a shot at modeling the weld geometry and accept all the baggage that entails but we'll discuss that more at the end of the session.



# Calculating Weld Size Using Loads

## Reduce actual loads to Load per Unit Length

TABLE 3 - DETERMINING FORCE ON WELD

Type of Loading	standard design formula	treating the weld as a line
	stress lbs/in <sup>2</sup>	force lbs/in
<b>PRIMARY WELDS</b> transmit entire load at this point		
	$\sigma = \frac{P}{A}$	$f = \frac{P}{A_w}$
	$\sigma = \frac{V}{A}$	$f = \frac{V}{A_w}$
	$\sigma = \frac{M}{S}$	$f = \frac{M}{S_w}$
	$\tau = \frac{T C}{J}$	$f = \frac{T C}{J_w}$
<b>SECONDARY WELDS</b> hold section together - low stress		
	$\tau = \frac{V a y}{I t}$	$f = \frac{V a y}{I_n}$
	$\tau = \frac{T}{2At}$	$f = \frac{T}{2A}$

A = area contained within median line.  
(\* applies to closed tubular section only.)

"Design of Weldments"  
James F. Lincoln Arc Welding Foundation  
Cleveland, OH 1963

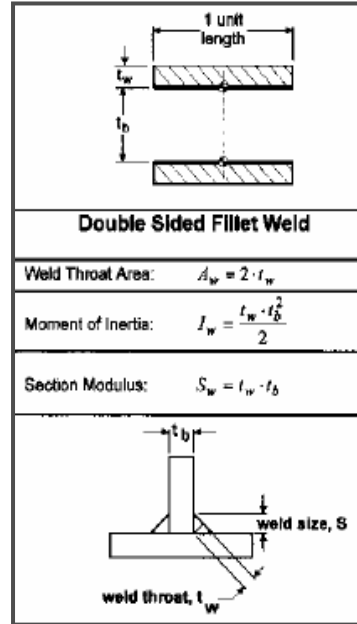

When welds are treated as lines,  $t_w = 1$ ; therefore:

$A_w = 2$

$S_w = t_b$

"Determination of Weld Loads & Throat Requirements Using FEA - A Comparison with Classical Analysis"  
Michael A. Weaver  
Welding Research Supplement  
www.weavereng.com

© 2006 SolidWorks Corp. Confidential.

As stated previously, the welds are idealized as lines, located in the case of a fillet weld, at the heel of the weld. The normal, shear, & bending forces can be calculated using simple equations based on a local "weld coordinate system". The equations for these loads are shown in the left hand table from the Lincoln Arc Welding Foundation's "Design of Weldments". The equations for Throat Area,  $A_w$ , and Section Modulus,  $S_w$ , are from a paper by Michael Weaver describing the adaptation of this technique for FEA but are available in other references. When a double fillet weld is reduced to a line, the weld area becomes 2 and the Section Modulus becomes the thickness of the leg component. We'll use this data in a detailed example.

The area and section modulus for other weld types are available and it is recommended that you obtain these references for your design work.

## Calculating Weld Size Using Loads



At any given location...

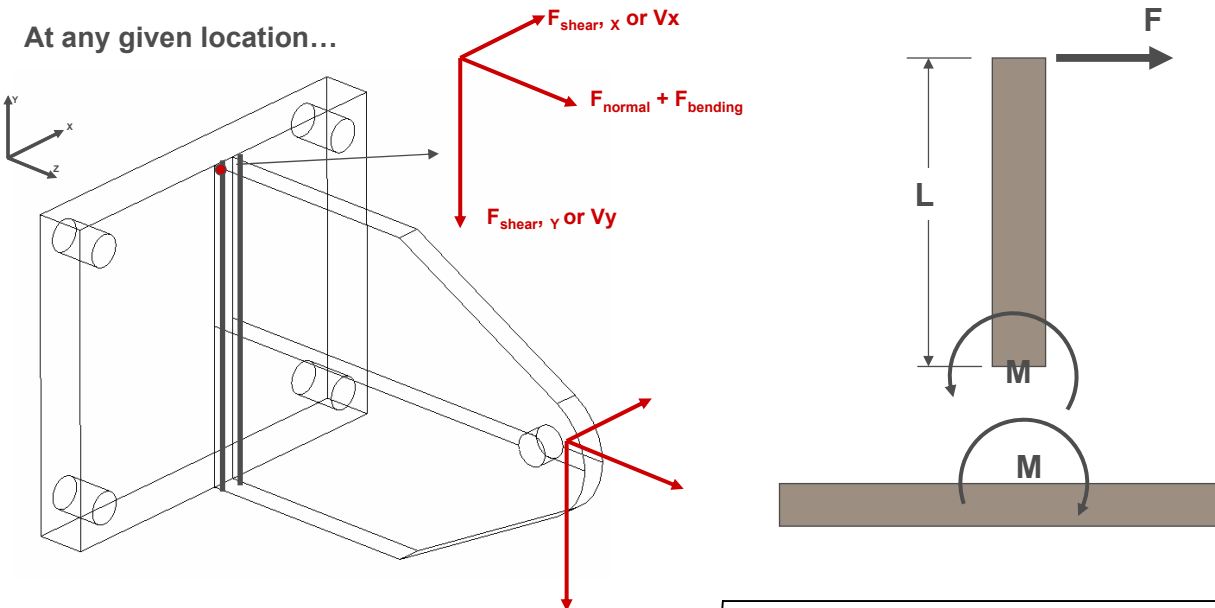

**'Per Unit Length' Loads:**

$$f_{shear} = V / A_w \text{ (Include both directions)}$$

$$f_{bending} = M / S_w$$

$$f_{normal} = F_{normal} / A_w$$

$$f_{weld} = \sqrt{\left(\frac{M}{t_b} + \frac{P}{2}\right)^2 + \left(\frac{V_x}{2}\right)^2 + \left(\frac{V_y}{2}\right)^2}$$

15

© 2006 SolidWorks Corp. Confidential.

In this example from the Weaver paper mentioned in the last slide, a t-joint will be subjected to a shear, normal and bending load. Using the equations from the previous slide, the actual applied loads can be converted to “per unit length” loads. These, in turn, can be combined vectorially in the final equation, shown in the lower right corner, to determine the sum of the squares resultant load per unit length on the weld. This calculation must be repeated at discrete points along the weld, not on the loads thru the whole weld or sections. This is important and some planning is required to get nodal values where you need them to be.

# Calculating Weld Size Using Loads

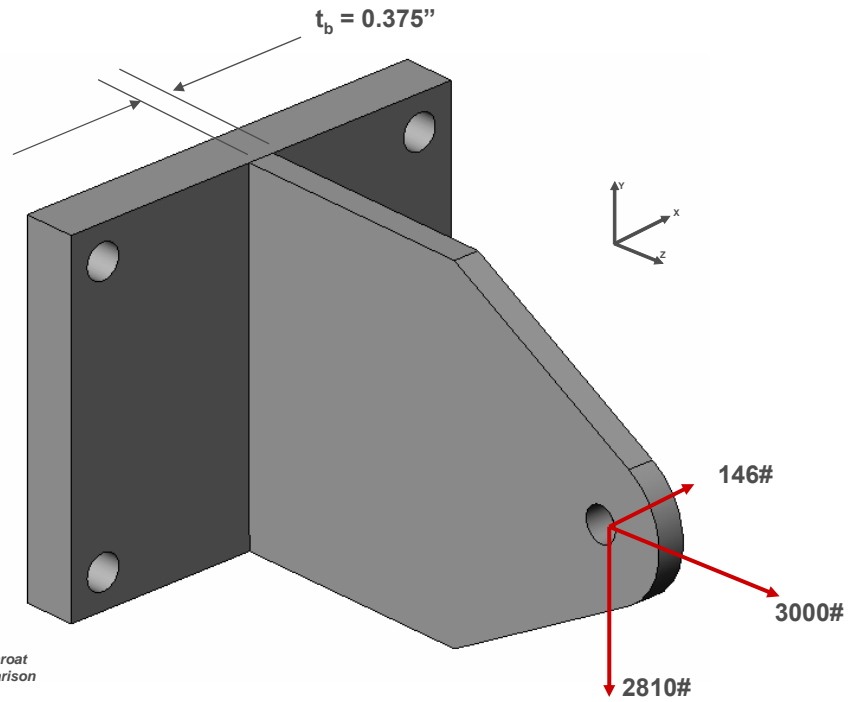

*"Determination of Weld Loads & Throat Requirements Using FEA – A Comparison with Classical Analysis"*  
Michael A. Weaver  
Welding Research Supplement  
www.weavereng.com

© 2006 SolidWorks Corp. Confidential.

16

The model will be constructed using the geometry & forces shown in this slide. The leg of the t-joint is 3/8ths of an inch thick.



## Calculating Weld Size Using Loads



- Build the shell model in COSMOSWorks
- If possible, estimate positions on each weld of maximum load
  - Use split lines to place evenly spaced vertices in these locations
- If not possible, solve the model and review areas of high stress to suggest weld study, place split lines and solve again
- Extract the Normal, Shear, and Bending FBD forces at vertices in areas of concern
- Vectorially combine the forces on the weld at this point
- Determine weld size by dividing resultant value by allowable load on weld

© 2006 SolidWorks Corp. Confidential.

17

The process we will follow in this example is outlined here. We'll elaborate on each of these steps.

It is preferable to use a shell model for these calculations. The loads are more readily obtained since points on the intersection edge are easy to access. The example will use shells but we'll talk more about solids at the end.

Try to determine areas where you expect the demand on the welds will be the highest. This can save you the trouble of evaluating every weld. If it isn't obvious, you should solve your model first and review the stresses on the welds for peak stresses on each weld. While the absolute magnitude is not reliable, you should be able to ascertain which areas will control weld size on the assembly.

In the areas you need to size welds, place split lines to force evenly spaced vertices on the weld seam. You'll need to put a minimum of 3 vertices in an area of concern and maybe more if the area is large. The spacing of these should be slightly less than the default mesh size used in the model.

Mesh the model with draft elements and review the mesh to make sure there is only one element edge between your placed vertices. Why draft elements? High quality elements have a mid-side node that will get placed between vertices so the load carried by the nodes on the vertices you placed will under-predict the actual demand in that area. Should you be concerned about stress accuracy with draft elements? No...that's the beauty of a force-based technique. The load thru the seam will not change much between high quality and draft elements if your element size is sufficiently small. Since you will most likely perform an initial study to check the location of high weld loads, run that with high quality elements. Save off images or create a new study for the weld sizing so that you can compare the results from this to the draft element mesh you'll use later. If there are glaring differences, reduce your mesh size. Most likely, the displacements will match although the stress levels at discontinuities will be lower with the draft mesh. Don't worry about that.

Make sure you enable "Compute Free Body Forces" in the study properties.

When your solution is complete, extract the forces at the vertices, convert them to "per unit length" loads, combine vectorially, and calculate your weld size by dividing the resultant force by the allowable strength.

This seems involved but you'll see in the solved example that it can go pretty quickly.

## Solid Model and Surfaces for Shells



- [-] T-joint Configuration(s) (Analysis<Display State-1>)
- [-] Analysis<Display State-1> [ T-joint ]
- [-] Default<Display State-1> [ T-joint ]

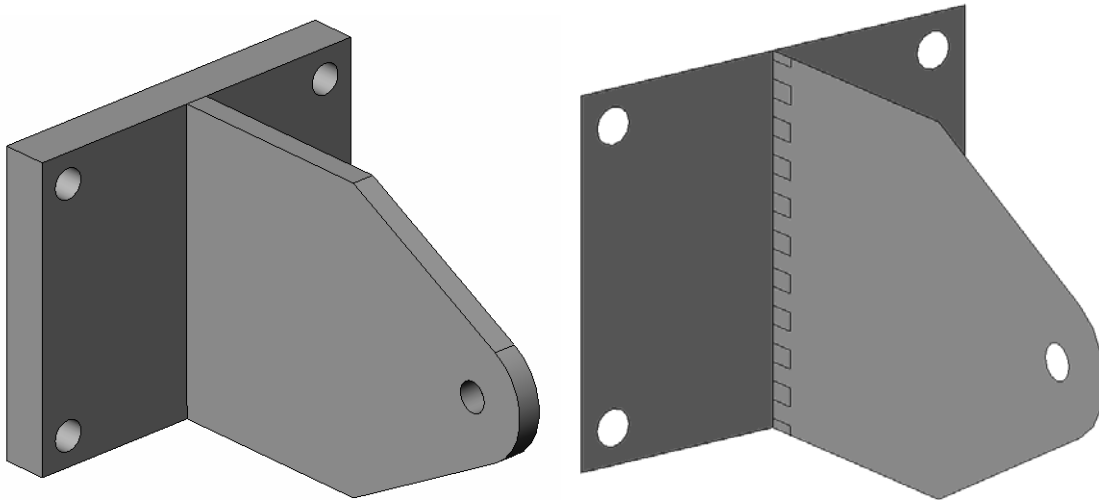

© 2006 SolidWorks Corp. Confidential.

18

This is the model used for the example. A solid model was created initially. A Configuration called Analysis was used to develop the analysis-specific geometry. If you use the Parent/Child Options in the new configuration dialog box, you can have SolidWorks create a configuration with the same name in each component automatically. This way, when you activate the assembly configuration, the parts will snap to that configuration too. Great for these types of problems.

A zero offset surface was created on the front of the back plate and a midsurface was added to the Leg component. The entire weld seam edge on the Leg component was divided using split lines to get the vertices need for the calculations.



## Why the Split Line?

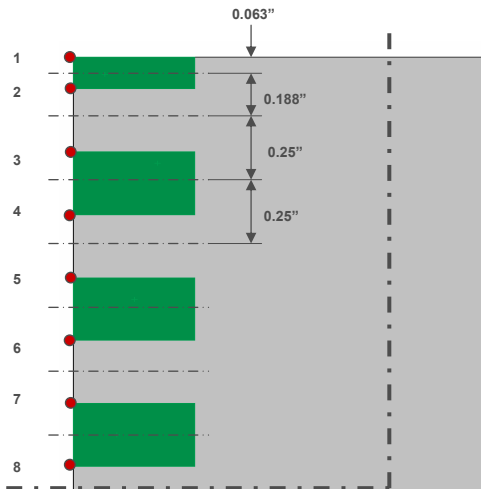

Point 1 carries load across **0.063"** of the edge  
 Point 1 carries load across **0.188"** of the edge  
 Point 3 carries load across **0.25"** of the edge  
 Etc...

The load transfer at the weld needs to be localized to a force per unit length value.

Nodal values required for this discrete output

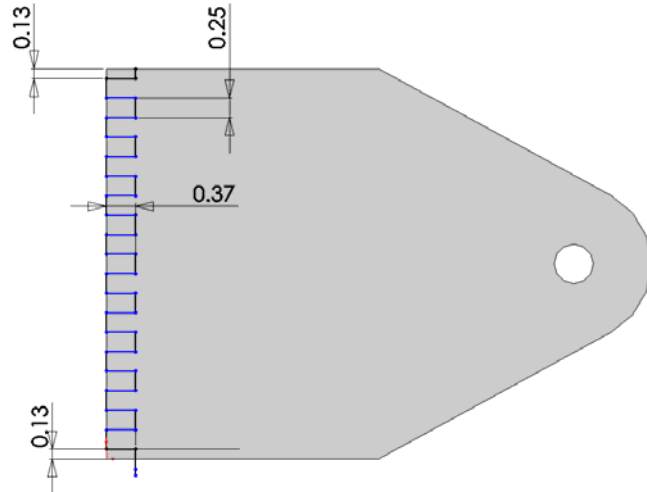

© 2006 SolidWorks Corp. Confidential.

19

The spacing of the vertices is important. The load per unit length of each vertex is determined by the distance from  $\frac{1}{2}$  way between that vertex and each of its adjacent vertices. For example, using the spacing shown, vertex #1 has no vertex above it so it carries load for the distance to the top edge or 0.063". Vertex #2 carries load for  $\frac{3}{16}$ <sup>th</sup> of an inch as shown and vertices 3-8 carry the load for 0.25 inches each. These distances will be important later in the calculations so plan your spacing to use reasonable dimensions.

In this case, I biased the points towards the edges of the part to get better load resolution where the load will be the highest. This is not required in all cases and, frankly, may not have been required here but the old analyst in me couldn't help messing with the details.

## Mesh at Interface



Due to Split Line on Back Plate, a Compatible Mesh is forced between the two components.

Mesh is sized so that nodes at interface correspond to Split Line vertices

(i.e. Default mesh size => Vertex Spacing)

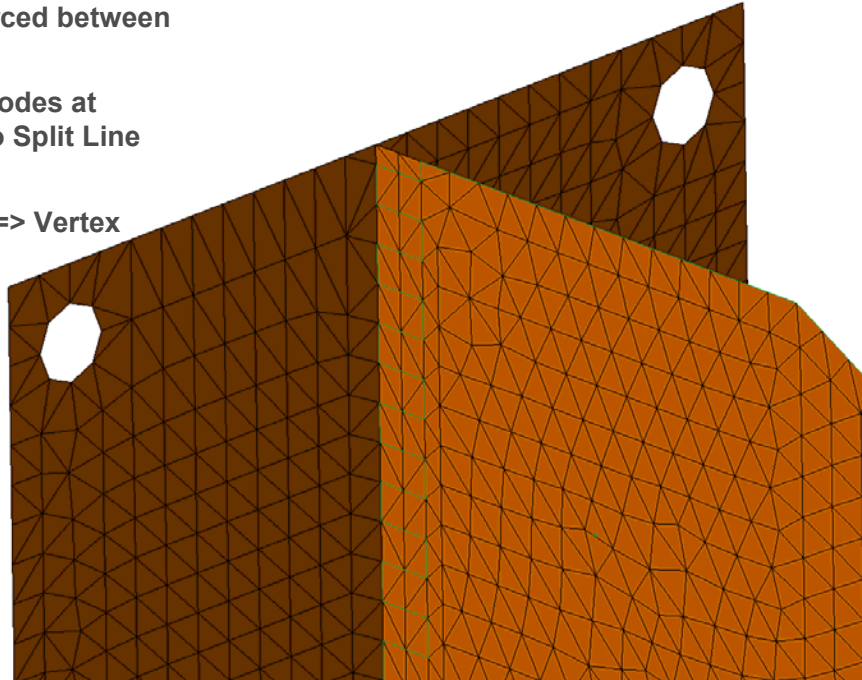

© 2006 SolidWorks Corp. Confidential.

20

Note that when the part is meshed, I have one element in each of the segments on the edge. Since these are draft elements, this ensures I have 1:1 node to vertex correspondence so that when I sum up the loads carried by the vertices, it will equal the applied load.

Also note that the mesh is *compatible* at the joint. This means that the nodes on both parts line up and are merged for a continuous mesh. This was achieved by splitting the Base Plate surface with a Split Line at the same place the Leg is attached. In a COSMOSWorks shell mesh, if two edges are co-linear, the meshes will be compatible and merge. This is more reliable and accurate for this application than bonded contact which allows an incompatible mesh. You don't have any control over which nodes actually carry the load in that case.

## Loads and Restraints

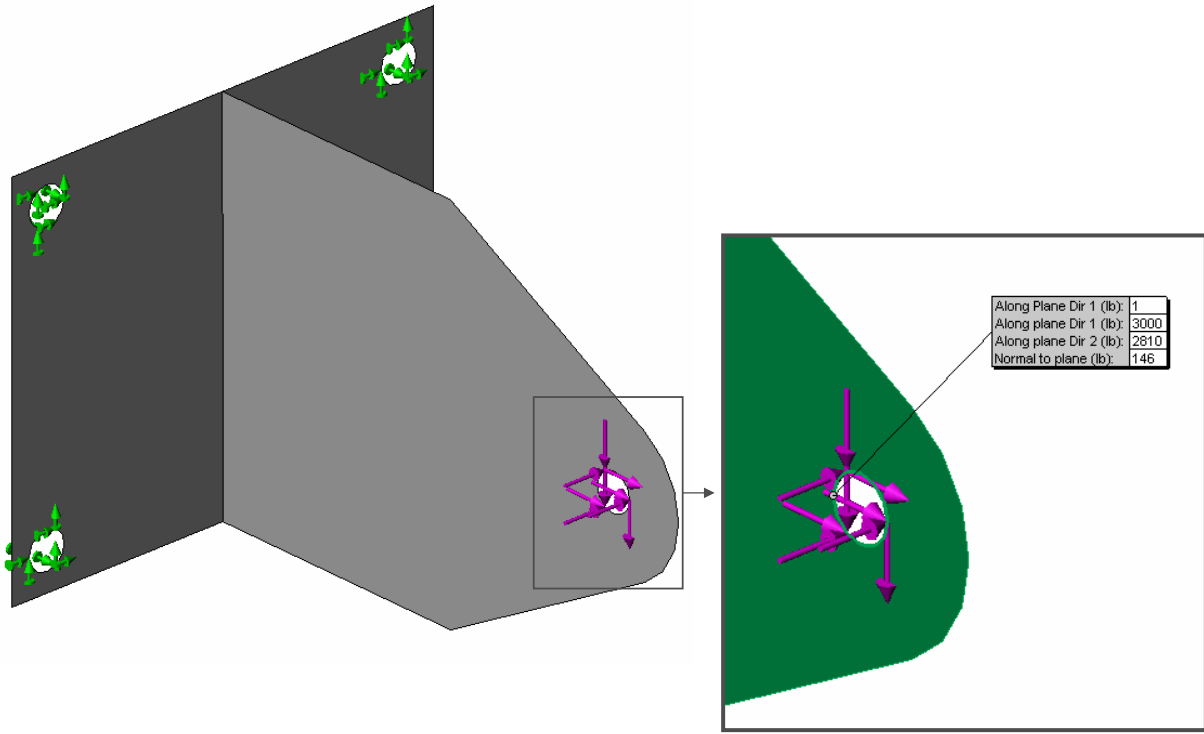

© 2006 SolidWorks Corp. Confidential.

21

The through-holes in the Back Plate were fixed and the load was applied to the edges of the hole in the Leg. This hole is far enough away from the weld that I don't expect this simplified load distribution will affect my results of interest. If I was simultaneously interested in the stress in the hole as well as the weld, I might want to put more thought into this load distribution. Actually, if I was concerned about stress at the hole, I'd probably evaluate it with a separate model more appropriate for the real problem and just use this model for the weld study.

## Compute Free Body Forces



- This must be enabled to extract the interface forces between the lug and the base plate
- FBD forces provide the load across faces, vertices & edges

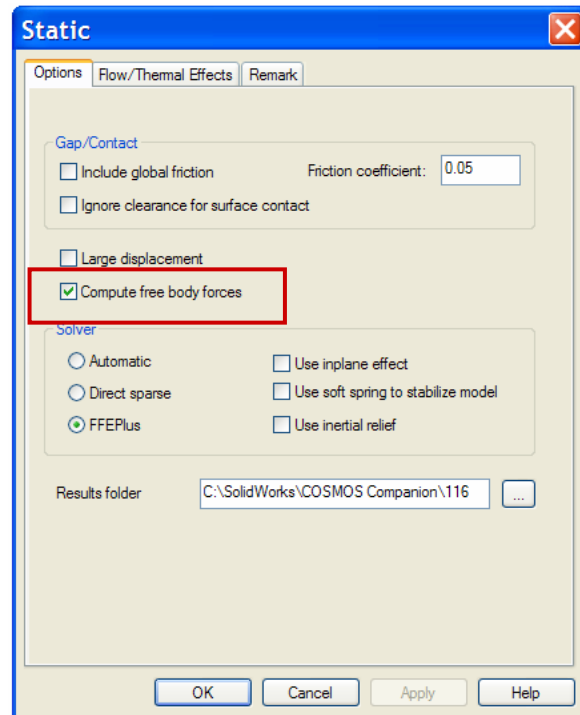

© 2006 SolidWorks Corp. Confidential.

22

New to v2007, the Compute Free Body Forces option in the Study Properties must be enabled to have COSMOSWorks calculate the loads needed at the vertices. This is an important enhancement in v2007.

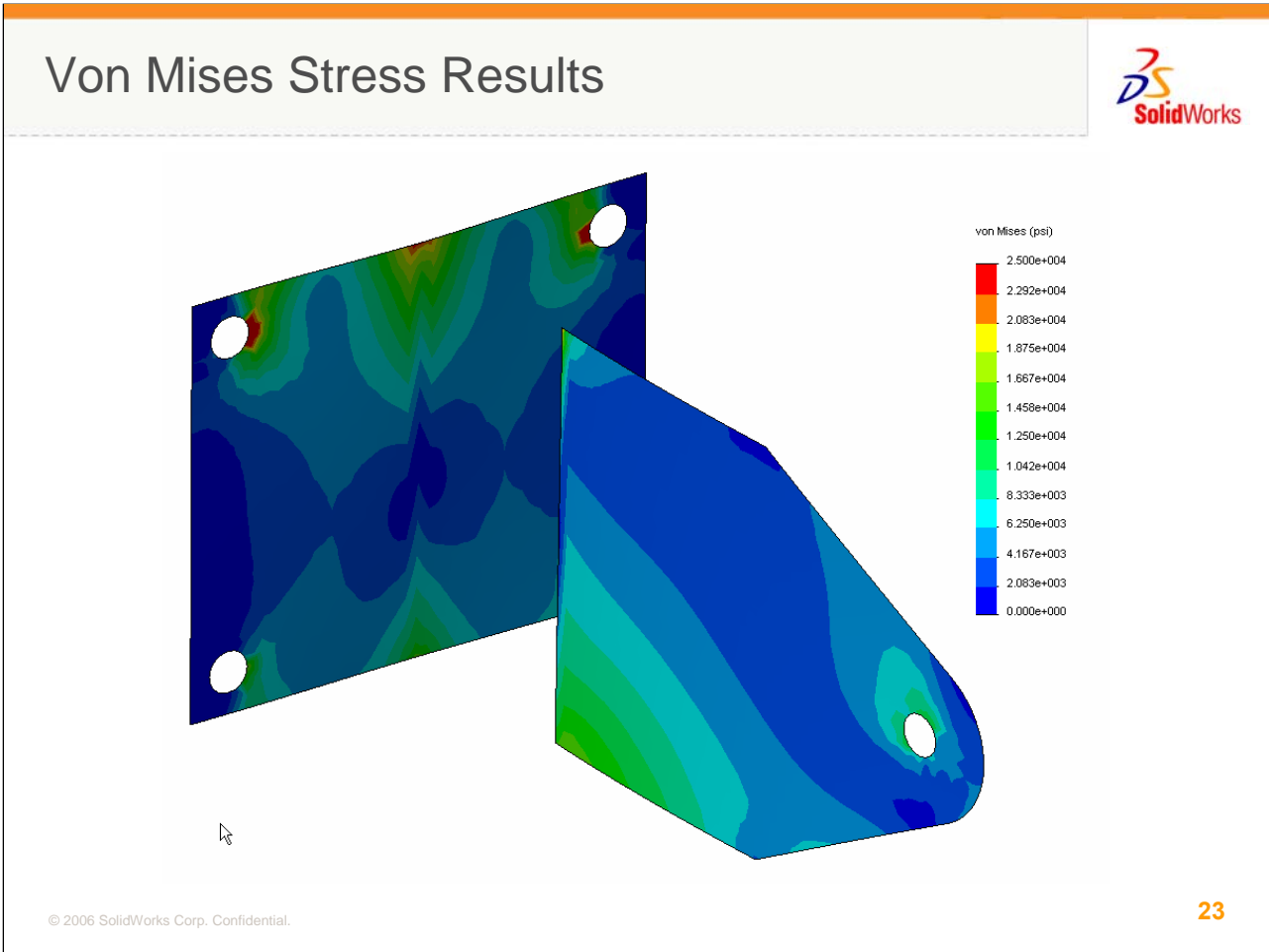

This is the Von Mises Stress plot from the solution. Note the high stress regions at the top and bottom of the Leg. We would expect the weld to be carrying a higher load in these areas than the center of the part.

## Loads on Weld



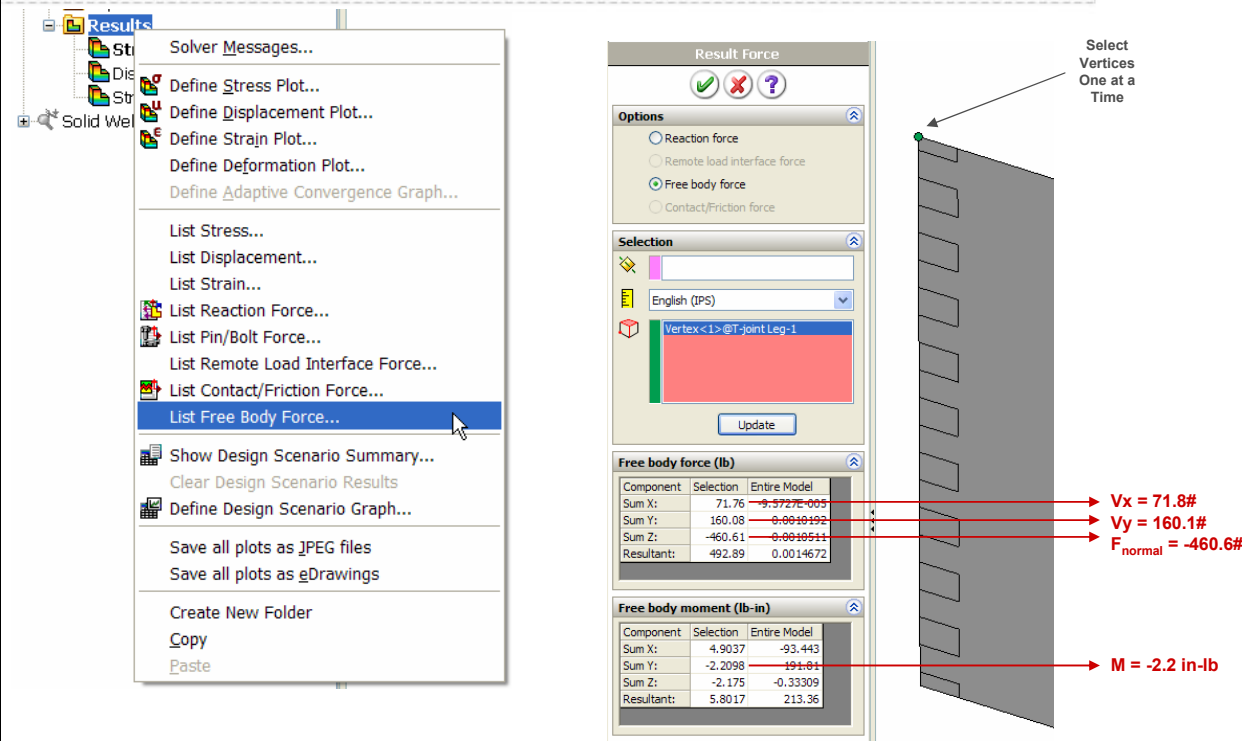

Select Vertices One at a Time

Component	Selection	Entire Model
Sum X:	71.76	-5.927E-005
Sum Y:	160.08	-0.0010492
Sum Z:	-460.61	-0.0010511
Resultant:	492.89	0.0014672

**V<sub>x</sub> = 71.8#**  
**V<sub>y</sub> = 160.1#**  
**F<sub>normal</sub> = -460.6#**

Component	Selection	Entire Model
Sum X:	4.9037	-93.443
Sum Y:	-2.2098	-194.84
Sum Z:	-2.175	-0.33309
Resultant:	5.8017	213.36

**M = -2.2 in-lb**

© 2006 SolidWorks Corp. Confidential.

**24**

To extract the free body forces, right mouse click the results folder. If you're new to v2007, you'll see a new layout to this menu. In fact, the Results folder in general has been streamlined so that you only see the plot you want to see. The List Free Body Force option is about ½ way down the list. When you choose it, you'll see the Result Force UI. Make sure Free body force is selected in the options and choose the top-most vertex, #1. Based on the assembly CS, the X, Y, & Z forces correspond to the X shear, Y shear, and normal forces. The Y moment is the bending moment we are concerned about in this model. While the X & Z moments are similar in size for this vertex, their effect is captured by the normal force above. Since shell elements do not have any real physical thickness, the moment about the shell edge is required to determine the force couple reacting out the moment.

Note these 4 load values in a spreadsheet for Vertex #1 and repeat for all the vertices of interest.

For more complex, multi-dimensional problems, you may want to change your nomenclature to represent a weld-specific CS since X, Y, & Z will not always mean, shear and normal forces. Normal, Lateral Shear, Longitudinal Shear, and Bending might be more widely applicable.





## Unit Length Load Calculations

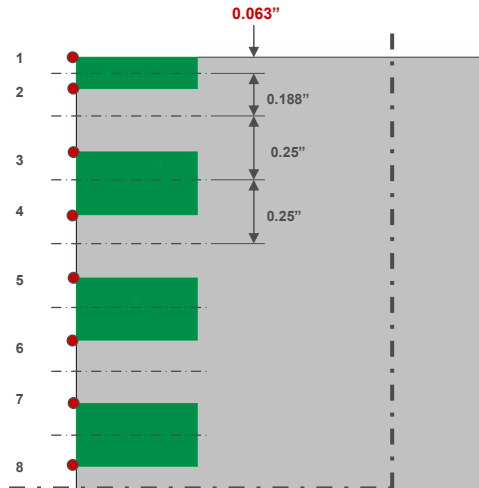

Vertex 1 carries load across 0.063 inches

$$f = F/L$$

$$f_x = 71.8\# / 0.063'' = \underline{1,139.7 \text{ lb/in}}$$

$$f_y = 160.1\# / 0.063'' = \underline{2,541.3 \text{ lb/in}}$$

$$f_n = -460.6\# / 0.063'' = \underline{-7,311.1 \text{ lb/in}}$$

$$M = -2.2 \text{ in-lb} / 0.063'' = \underline{-34.9 \text{ in-lb/in}}$$

Repeat for all vertices in area of concern

© 2006 SolidWorks Corp. Confidential.

25

Each load component, 4 loads per vertex, need to be converted to “per unit length” forces by dividing them by the spacing between the vertices. Note again, that this is the distance between the adjacent midpoints, not the actual vertex-to-vertex spacing.

Repeat this for all vertices.



## Unit Length Load Calculations

$$f_{shear} = V / A_w \text{ (Include both directions)}$$

$$A_w = 2$$

$$f_{bending} = M / S_w$$

$$f_{normal} = F_{normal} / A_w$$

$$S_w = t_b = 0.375$$

$$f_{weld} = \sqrt{\left(\frac{M}{t_b} + \frac{P}{2}\right)^2 + \left(\frac{V_x}{2}\right)^2 + \left(\frac{V_y}{2}\right)^2}$$

$$f_{weld} = \sqrt{\left(\frac{-34.9}{0.375} + \frac{-7,311.1}{2}\right)^2 + \left(\frac{-1,139.7}{2}\right)^2 + \left(\frac{2,541.3}{2}\right)^2}$$

$$\mathbf{f_{weld} = 3,958.2 \text{ lb/in}}$$

© 2006 SolidWorks Corp. Confidential.

26

Once these 'per unit length' force components have been computed, they need to be converted to the line loads indicated by the references. For a double-sided fillet weld, we'll use the equations listed previously. You'll need to review the applicable references for the loads for your weld type. Again, these calculations can be automated in a spreadsheet for all the vertices being studied in the model. In this case, the resultant vector force at vertex #1 is about 4,000#.

## Unit Length Load Calculations



$$\text{Weld Throat} = \frac{\text{Resultant Load/Unit Length}}{\text{Allowable Strength/Unit Length}}$$

**Allowable Strength = 13,100 psi per AWS D1.1  
for Double Fillet Weld & E60 Electrode**

$$t_w = 3,958.2 \text{ lb/in} / 13,100 \text{ psi/in} = 0.302 \text{ in}$$

$$\text{Weld Size, } S_w = \sqrt{2} * t_w = \underline{0.427 \text{ in.}}$$

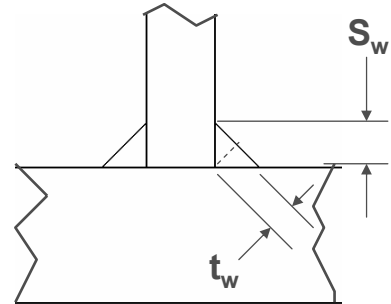

**Repeat for all vertices in area of concern**

© 2006 SolidWorks Corp. Confidential.

27

The Weld Throat,  $t_w$ , required to carry this load is determined by dividing the previously calculated resultant force by the allowable strength, in per unit length terms, specified by the references. AWS D1.1 has tabulated many of these values by weld type, steel type, and electrode type. In this example using A36 steel, a double-sided fillet weld, and an E60 electrode, the allowable strength is 13,100 psi. Dividing the 4,000# by 13,100 psi yields a throat of 0.3 inches. To determine the weld size based on this throat, multiply the throat dimension by the square root of 2. In this case, a weld of 0.427" is required at vertex #1 to carry the applied load.

Again, this must be repeated for all vertices of concern. Automating the calculations in a spreadsheet makes this repetitive task trivial.

# Completed Calculations



	V <sub>x</sub>		V <sub>y</sub>		F <sub>norm</sub>		M					
	FX	FX/in	FY	FY/in	FZ	FZ/in	MY	MY/in		Resultant	Leg, tw	Weld Size
1	71.8	1,139.7	160.1	2,541.3	-460.6	-7,311.1	-2.2	-34.9		3,958.3	0.302	0.427
2	9.6	51.1	132.0	702.1	-988.0	-5,255.3	-23.8	-126.6		2,986.0	0.228	0.322
3	-28.5	-114.0	157.8	631.2	-1,054.6	-4,218.4	-37.1	-148.4		2,524.8	0.193	0.273
4	-23.2	-92.8	164.1	656.4	-872.5	-3,490.0	-43.6	-174.4		2,234.3	0.171	0.241
5	-18.0	-72.0	157.4	629.6	-752.1	-3,008.4	-44.8	-179.2		2,006.9	0.153	0.217
6	-18.2	-72.8	153.6	614.4	-596.3	-2,385.2	-47.3	-189.2		1,724.7	0.132	0.186
7	-15.1	-60.4	148.3	593.2	-484.9	-1,939.6	-47.4	-189.6		1,504.9	0.115	0.162
8	-13.8	-55.2	142.5	570.0	-383.2	-1,532.8	-47.7	-190.8		1,306.7	0.100	0.141
9	-13.1	-52.4	135.3	541.2	-295.7	-1,182.8	-47.8	-191.2		1,134.0	0.087	0.122
10	-11.6	-46.4	128.3	513.2	-216.5	-866.0	-47.7	-190.8		976.1	0.075	0.105
11	-13.0	-52.0	122.1	488.4	-142.7	-570.8	-48.1	-192.4		835.0	0.064	0.090
12	-11.4	-45.6	115.7	462.8	-77.1	-308.4	-47.7	-190.8		702.2	0.054	0.076
13	-13.2	-52.8	111.7	446.8	-10.0	-40.0	-48.1	-192.4		578.0	0.044	0.062
14	-12.8	-51.2	108.3	433.2	55.7	222.8	-47.9	-191.6		454.5	0.035	0.049
15	-14.0	-56.0	106.7	426.8	125.7	502.8	-47.7	-190.8		334.4	0.026	0.036
16	-13.8	-55.2	106.7	426.8	202.7	810.8	-47.1	-188.4		234.5	0.018	0.025
17	-17.6	-70.4	107.9	431.6	292.0	1,168.0	-47.0	-188.0		231.3	0.018	0.025
18	-19.6	-78.4	110.9	443.6	395.4	1,581.6	-45.9	-183.6		374.2	0.029	0.040
19	-23.1	-92.4	114.5	458.0	524.8	2,099.2	-43.8	-175.2		625.9	0.048	0.068
20	-29.5	-118.0	116.9	467.6	690.1	2,760.4	-39.1	-156.4		991.2	0.076	0.107
21	8.6	45.7	70.8	376.6	672.7	3,578.2	-20.0	-106.4		1,517.1	0.116	0.164
22	73.9	1,173.0	138.2	2,193.7	348.1	5,525.4	-4.0	-63.5		2,816.0	0.215	0.304
<b>Sum</b>	<b>-145.6</b>		<b>2809.8</b>		<b>-3027</b>		<b>-875.8</b>					

© 2006 SolidWorks Corp. Confidential.

This spreadsheet shows the computations for the entire weld seam. The boxed columns are the data pulled from the Free Body loads on the vertices. The calculations for Vertex #1 are also boxed at the top of the table. Again, once the spreadsheet is developed and the data pulled from COSMOSWorks, filling in the sheet is fairly quick.

## Minimum Weld Size Along Weld

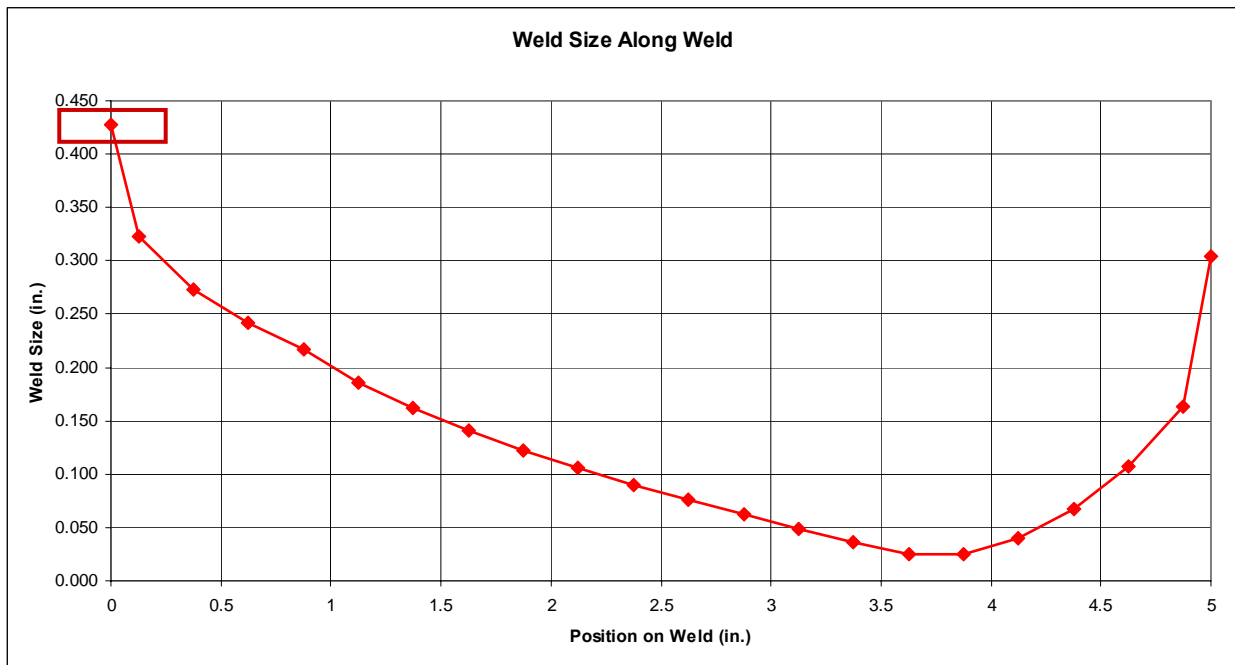

© 2006 SolidWorks Corp. Confidential.

29

Plotting the weld size along the length of the weld confirms that the edges carry the greatest load and need to be the largest. Since most welds of this type will be spec'd to be uniform along the length, you should choose the highest weld size, 0.427 inches, for the entire weld.

The large swing in demand along the length of the weld might even suggest a skip or intermittent weld for this joint. Remember that to check this, you'll need to re-run your model with the area that isn't welded freed up. This can be handled with more creative split lines.

# Completed Calculations



	FX	FX/in	FY	FY/in	FZ	FZ/in	MY	MY/in		Resultant	Leg, tw	Weld Size
1	71.8	1,139.7	160.1	2,541.3	-460.6	-7,311.1	-2.2	-34.9		3,958.3	0.302	0.427
2	9.6	51.1	132.0	702.1	-988.0	-5,255.3	-23.8	-126.6		2,986.0	0.228	0.322
3	-28.5	-114.0	157.8	631.2	-1,054.6	-4,218.4	-37.1	-148.4		2,524.8	0.193	0.273
4	-23.2	-92.8	164.1	656.4	-872.5	-3,490.0	-43.6	-174.4		2,234.3	0.171	0.241
5	-18.0	-72.0	157.4	629.6	-752.1	-3,008.4	-44.8	-179.2		2,006.9	0.153	0.217
6	-18.2	-72.8	153.6	614.4	-596.3	-2,385.2	-47.3	-189.2		1,724.7	0.132	0.186
7	-15.1	-60.4	148.3	593.2	-484.9	-1,939.6	-47.4	-189.6		1,504.9	0.115	0.162
8	-13.8	-55.2	142.5	570.0	-383.2	-1,532.8	-47.7	-190.8		1,306.7	0.100	0.141
9	-13.1	-52.4	135.3	541.2	-295.7	-1,182.8	-47.8	-191.2		1,134.0	0.087	0.122
10	-11.6	-46.4	128.3	513.2	-216.5	-866.0	-47.7	-190.8		976.1	0.075	0.105
11	-13.0	-52.0	122.1	488.4	-142.7	-570.8	-48.1	-192.4		835.0	0.064	0.090
12	-11.4	-45.6	115.7	462.8	-77.1	-308.4	-47.7	-190.8		702.2	0.054	0.076
13	-13.2	-52.8	111.7	446.8	-10.0	-40.0	-48.1	-192.4		578.0	0.044	0.062
14	-12.8	-51.2	108.3	433.2	55.7	222.8	-47.9	-191.6		454.5	0.035	0.049
15	-14.0	-56.0	106.7	426.8	125.7	502.8	-47.7	-190.8		334.4	0.026	0.036
16	-13.8	-55.2	106.7	426.8	202.7	810.8	-47.1	-188.4		234.5	0.018	0.025
17	-17.6	-70.4	107.9	431.6	292.0	1,168.0	-47.0	-188.0		231.3	0.018	0.025
18	-19.6	-78.4	110.9	443.6	395.4	1,581.6	-45.9	-183.6		374.2	0.029	0.040
19	-23.1	-92.4	114.5	458.0	524.8	2,099.2	-43.8	-175.2		625.9	0.048	0.068
20	-29.5	-118.0	116.9	467.6	690.1	2,760.4	-39.1	-156.4		991.2	0.076	0.107
21	8.6	45.7	70.8	376.6	672.7	3,578.2	-20.0	-106.4		1,517.1	0.116	0.164
22	73.9	1,173.0	138.2	2,193.7	348.1	5,525.4	-4.0	-63.5		2,816.0	0.215	0.304
Sum	-145.6		2809.8		-3027		-875.8					

- Weld sizing is a linear calculation. Size at any given point not dependent upon response of the entire weld.
- This allows the calculation to be localized

© 2006 SolidWorks Corp. Confidential.

Another important characteristic of this method is that the results for any given vertex are independent of the calculations for the other vertices. This fact allows the method to be localized so you only need to generate a few vertices in areas of concern and don't need to plot out the loads for the entire weld as we did here. Using this knowledge can save you a lot of time.



# Plots of Combined Force and Model Stress

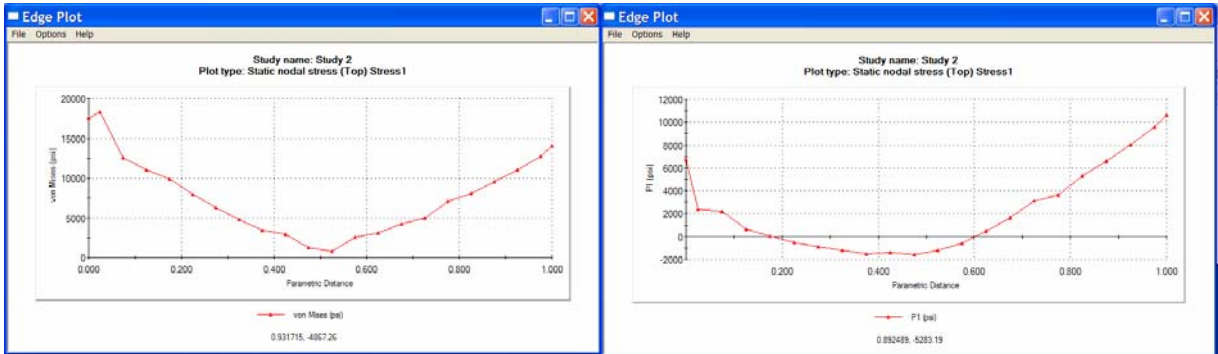
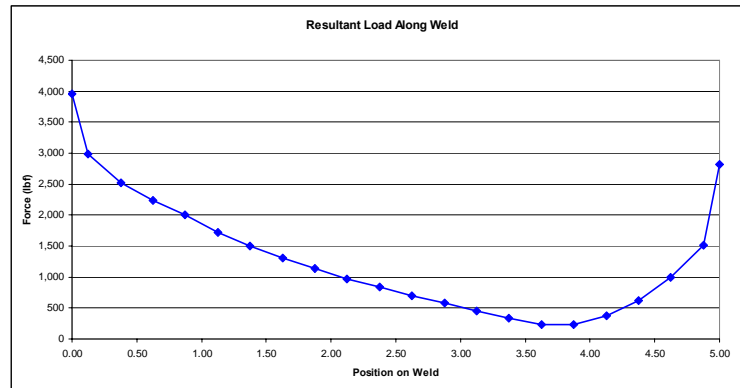

© 2006 SolidWorks Corp. Confidential.

These plots compare the Von Mises and P1, or Max Principal, stresses along the weld to the resultant load. You'll note there isn't a 1:1 correspondence between either of these stress curves and the load used to calculate weld size. The free body forces are clearly the way to go. However, the curves are similar in shape suggesting stress can be used to determine the areas of concern for weld sizing so you can localize the calculations.

## Wrap-Up on Weld Size Calculations



- Looks complex to even experienced analysts
  - Not so bad once you've done it a few times
  - What are your other options?
- Using FBD Loads currently requires individual vertex selection
  - Set up you split lines carefully
- On a complex weldment, you may need to check this in several places – Stresses are not reliable indicators of demand on weld
- Load path through weld is critical. Shells are preferred but sometimes they aren't an option

© 2006 SolidWorks Corp. Confidential.

32

That was a lot of information in a relatively condensed format so let's recap the process and some of the important points. This isn't a push-button technique yet. If you have grown accustomed to the relative ease of a COSMOSWorks analysis, this may seem a little over-whelming to you. It was to us when we were working through it the first time. However, it really isn't so bad once you've been through it a few times. And let's face it, what other options do you have? Stress results in your finite element model are not sufficient for predicting weld requirements. If that is the only thing you learn from this session, it will have been worth your time. However, this technique is pretty straightforward and based on proven methods so it is worth learning.

Remember that your weld estimates are only as good as the loads calculated at the welds. Getting your loads and restraints right is still critical for this to succeed. While the force method somewhat insensitive to mesh size, depending on geometry complexity, it is still highly sensitive to your loads and restraints since they determine the load path in the model.

Extracting the forces does require nodal values which can be determined from the free body loads at vertices if you've placed your split lines properly. Use draft elements sized in conjunction with your vertex spacing to ensure there are no nodes between your vertices. Use local mesh control if you have to.

An important fact of life is that if you have a large assembly with lots of welds, you need to examine all of them. This doesn't mean that you need to calculate weld size for all nodes on all welds. If you know you'll be specifying a consistent weld size in multiple regions of the assembly for manufacturing reasons, use the stresses from the initial run to find the controlling areas and perform the calculations in these spots. The number of welds that need to be examined is a problem-specific value. Only you can be sure if you've covered enough ground on your problem.

Finally, this method is most applicable to shells meshes since they simplify the load extraction. Unfortunately, in many cases, solids are the only way to go. This technique can be adapted to solids with even more creative split-lining but you'll need to run some test runs on simple problems to ensure you're getting reliable answers.



## Alternate Modeling Methods for Welds



### 1. Disengage contact where penetration stops

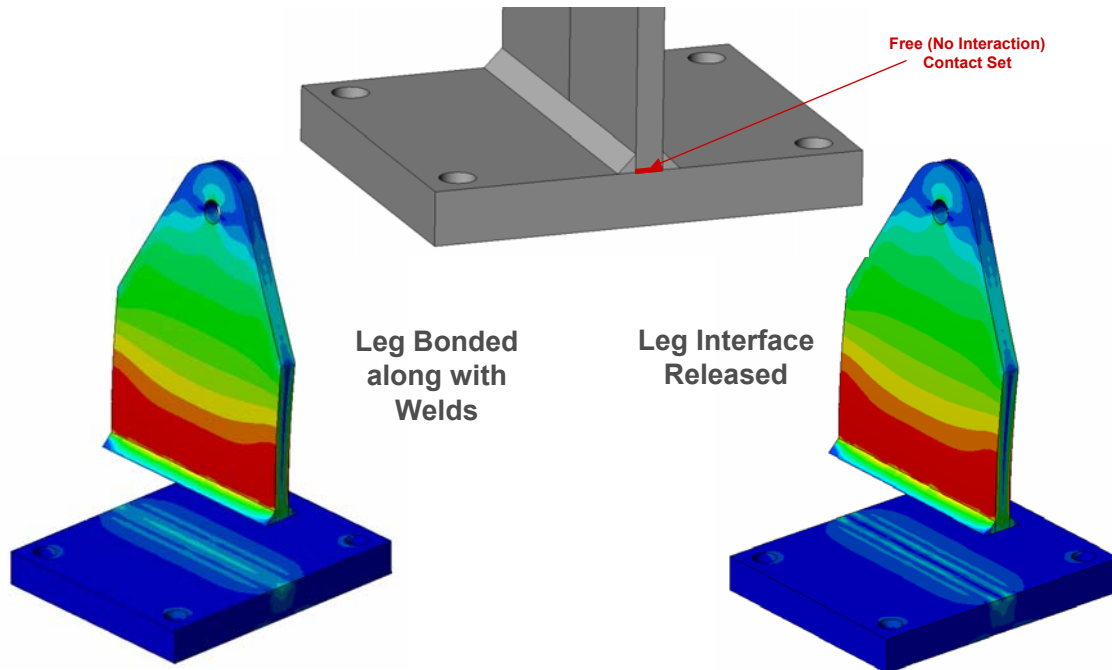

© 2006 SolidWorks Corp. Confidential.

33

If you need to model your weldment with solid elements, here are some options for modeling techniques to help get more reliable loads. Again, try to ignore the stresses computed on these solid models. Trust me...it's hard since they're right there and look reasonable. Focus on the forces.

First of all, you must acknowledge that some welds are full penetration and the forces through the welds will be dependent upon the contact area of the weld. Trying to force an edge bond with solids can result in an unstable model so adding your best guess for weld size is unavoidable. Keep in mind that this may require a few iterations. If you build your model with a 1/4 " weld and the sizing calculations suggest a 1/2" weld, you should resize your model and re-run the calculations to see if anything changed.

Back to the full vs. partial penetration issue, it is common on solid welded assemblies to set your global contact to bonded. In this case, you can simply manually define a contact set between the mating edge of the T leg and the Base as Free so that all the load goes thru the weld bonds. If you prefer to set global contact to free and use Find Contact Sets to select the bonded pairs, (as I do), simply deselect the contact pair at the end of the T.

The images in this slide show, at least from a stress standpoint (in an exploded view), the stress distribution, and thus the load path, does vary noticeably with the middle area freed up.

## Alternate Modeling Methods for Welds



### 2. Split Faces where High Load Expected

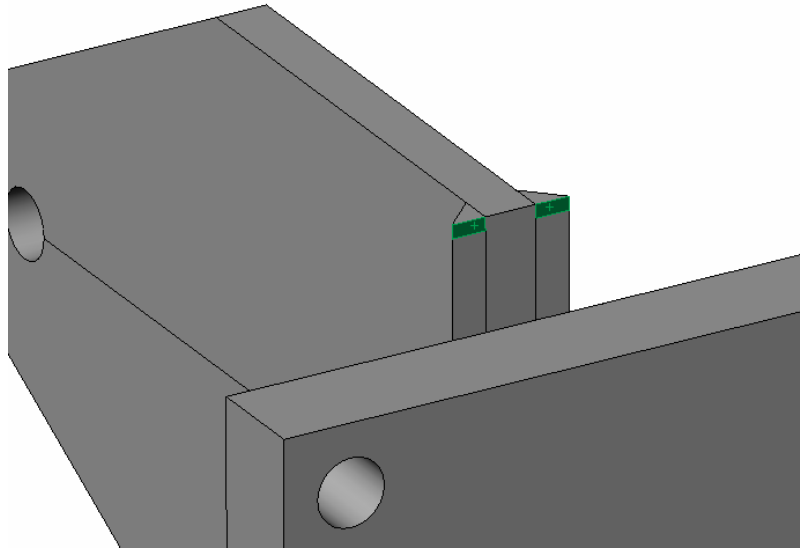

© 2006 SolidWorks Corp. Confidential.

34

Since you don't have the benefit of a line interface as you do with shells, selecting vertices is not an option. Therefore, you need to create some intelligently placed split lines so you can estimate the loads where the weld demand is the highest. As shown in this image, knowing the area of concern is at the ends, you can split the bottom of the weld bead to isolate forces in a known length of the weld.

## Alternate Modeling Methods for Welds



### 3. Extract FBD Forces on these faces and use for Load Calculations

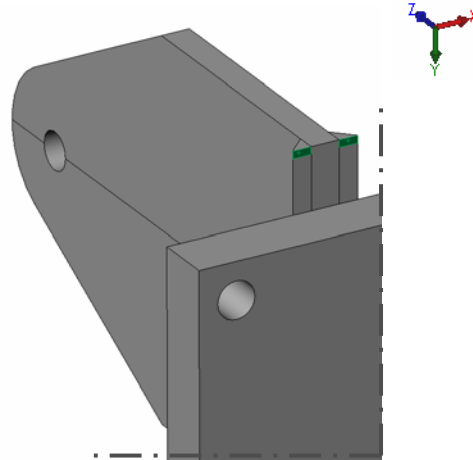
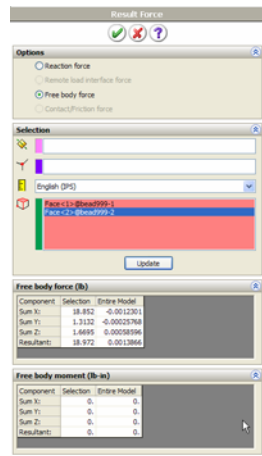

- Include both faces to be consistent with shell method
- Bending load accounted for in normal load

© 2006 SolidWorks Corp. Confidential.

35

You need to split both sides and the free body forces calculation should use both faces since the shell model line accounts for both faces. The bending moment is not calculated for solids and since there is depth in the thickness direction, the normal forces will include the bending component so that's covered.

Again, this is a work-around technique for using solids instead of shells where necessary. If you can get a shell representation for the weldment, your calculations will be more reliable. I highly suggest that you practice this technique on simple problems such as this one and compare the results between shell models and solid models. You may need to make some adjustments to the calculations or add some scale factors to get equivalent loads. Again, this may be case dependent.

## Alternate Modeling Methods for Welds



### 4. Include weld bead geometry for:

- Stiffness
- Load Transfer
- Weight (if gravity or acceleration loads used)
- NOT to review stresses on welds

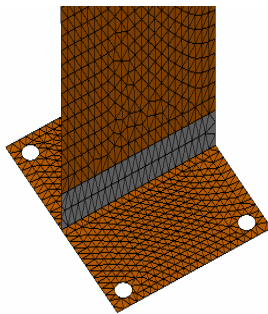

Include In-Line Weld Surface with Independent Thickness

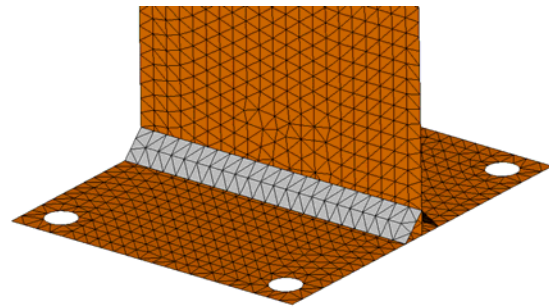

Include Angled Surfaces for Weld Leg Load Distribution

© 2006 SolidWorks Corp. Confidential.

36

Lastly, a common question is still, when should I model the weld bead if the calculations don't need it and the stresses calculated aren't reliable? Actually, as long as you acknowledge the stresses aren't reliable, it doesn't hurt to model the weld bead. There are many instances where the weld volume and section can impact the macro level results and should be included. If the weld is stiff compared to the base components, it may impact your displacements. If the weld mass is significant and gravity or accelerations loads are in your model, this mass may be important. In many cases the load transfer due to the weld geometry is different than without it. Only you can decide if these factors are important.

Adding the weld bead for solid models is pretty straightforward. However, there are a few different methods for including it in shell models. Two of the more popular methods are shown here. In the left image, a separate surface is added corresponding to the gap between midsurfaces or the anticipated height of the weld. The shell thickness of this surface can be specified to represent the mean weld bead thickness or, as some manufacturers do, specify a thickness equal to the weaker of the two components.

The second method is to add surfaces that represent the outer faces of the weld bead. This gives a more representative load transfer of the weld is large compared to the base geometry.

In both of these cases, don't forget that the intent is load transfer and global stiffness. You shouldn't put any faith in the results local to the weld.

## Presentation Summary...



- In this COSMOS Companion unit, we reviewed:
  - Several reasons why modeled welds WILL NOT give useable stress results
  - The Throat Shear method for determining weld sizes through transferred loads at the interface
  - A detailed description of the technique within COSMOSWorks
  - The “Include FBD Forces” option – New in v2007
  - Additional modeling considerations when the model must be in solids
  - Additional modeling considerations for including the weld bead in your model
  - Weld Calculations for **Static** loading – Fatigue will be covered in upcoming COSMOS Companion unit

© 2006 SolidWorks Corp. Confidential.

37

This wraps up our discussion of static analyses of welds and weldments in COSMOSWorks. The techniques required to predict fatigue robustness for welds is quite different and we'll cover that in a subsequent unit.

We focused the discussion on 3 areas. First, we emphasized, maybe to the point of overkill, that the stresses calculated on weld geometry in COSMOSWorks or any FEA tool are not reliable since welds themselves are nearly impossible to completely characterize. If you have been making weld sizing decisions based on these results in the past, you may have been lucky. Acknowledging that stresses on welds in an analysis model are only suitable for trend studies, we turned our attention to a force based method for estimating the demand on a weld. Forces are less sensitive to mesh convergence and local geometry and are consistent with more traditional techniques for sizing welds. The force based, Throat Shear method utilizes the new Free Body Forces output in v2007 so we reviewed that UI.

Finally, we talked about alternate modeling methods if your model doesn't lend itself to a shell representation with some warnings that you should validate this for your problems using test models to ensure the shell and solid results are comparable. We also reviewed some common modeling techniques for including the weld bead in a shell model if you need to include it for stiffness or weight reasons.

## Conclusion



For more information...

- Contact your local reseller for more in-depth training or support on using COSMOSWorks to model shell assemblies or to discuss the analysis of welds
- Review the on-line help for a more detailed description of the features discussed
- Attend, or better yet, present at a local COSMOS or SolidWorks user group.
  - See <http://www.swugn.org/> for a user group near you
- Good resources for weld design and analysis:
  - Lincoln Welding Foundation “Design of Weldments” [www.jflf.org](http://www.jflf.org)
  - American Welding Society [www.aws.org](http://www.aws.org)

© 2006 SolidWorks Corp. Confidential.

38

I'd like to thank you for taking the time to join in this edition of the COSMOS Companion. I hope this has opened your eyes a little to the complexities of modeling weldments in COSMOSWorks or any FEA package. This topic has been well researched in several industries and a web search on weld stresses and FEA will yield hours of enjoyable reading. If cyclic loading on your welds is an issue, stay tuned for a follow up session where we'll talk about analyzing welds for fatigue.

I encourage you to talk thru your problem, model setup and other modeling options with the support team at your local reseller and take advantage of their experience in using COSMOSWorks. Since shell models are an important aspect of weld analysis, you may want to review the techniques for modeling sheet metal assemblies as shells with your reseller support or review COSMOS Companion Unit # 111 for tips on these types of problems.

As always, I encourage you to get involved in a local COSMOS user group. This is one of the best vehicles for sharing and learning from the experience of others who face the same challenges as you. You can locate a local COSMOS group on the SolidWorks User Group network website shown. If there aren't any COSMOS groups near you, get involved in your local SolidWorks groups and introduce some COSMOS related topics to foster some discussion on design analysis and validation.

Finally, I've listed a couple of references that have been helpful to me in my years of analyzing welds and weldments. The Lincoln reference by Blodgett is over 40 years old but packed with the wisdom of years of weldment design experience. I'd also encourage you to get copies of the applicable AWS standards to get access to the allowables that are appropriate to your weld problems.

With that, I'd like to thank you again for your time and interest and I look forward to seeing you next time on the COSMOS Companion.